

AMERICAN BOARD OF ANESTHESIOLOGY
AMERICAN SOCIETY OF ANESTHESIOLOGISTS

IN-TRAINING EXAMINATION

Book A
1996

PREPARED IN COOPERATION WITH NATIONAL BOARD OF MEDICAL EXAMINERS®

DIRECTIONS: Each of the numbered items or incomplete statements in this section is followed by answers or by completions of the statement. Select the ONE lettered answer or completion that is BEST in each case and fill in the circle containing the corresponding letter on the answer sheet.

1. Coughing that occurs during awake intubation is prevented by local anesthetic block of which of the following nerves?

- (A) Glossopharyngeal
- (B) Hypoglossal
- (C) Recurrent laryngeal and glossopharyngeal
- (D) Recurrent laryngeal and superior laryngeal
- (E) Superior laryngeal and glossopharyngeal

2. Which of the following is the most common initial manifestation of malignant hyperthermia?

- (A) Hyperkalemia
- (B) Increased distal esophageal temperature
- (C) Increased PETCO₂
- (D) Red discoloration of urine
- (E) Ventricular irritability

3. Which of the following will most closely mimic the effects of stellate ganglion block?

- (A) Axillary perivascular block with 25 mL of 1.5% lidocaine
- (B) Cervical nerve block at C2-5 with 2 mL of 1.5% lidocaine
- (C) Supraclavicular block at the level of the first rib with 25 mL of 1.5% lidocaine
- (D) Block of the median, radial, ulnar, musculocutaneous, and intercostobrachial nerves
- (E) Excision of thoracic sympathetic ganglia T1-4

4. Postdural puncture headache occurs most commonly in which of the following patients?

- (A) Children
- (B) Elderly persons
- (C) Men
- (D) Parturients
- (E) Persons with obesity

5. The highest serum fluoride levels are seen following the administration of which of the following volatile anesthetics?

- (A) Desflurane
- (B) Enflurane
- (C) Halothane
- (D) Isoflurane
- (E) Sevoflurane

6. The initial reduction in core temperature during general anesthesia is caused by
- (A) ablation of thermoregulatory vasoconstriction
 - (B) conductive heat loss
 - (C) evaporative heat loss in the respiratory tract
 - (D) neuromuscular blockade
 - (E) redistribution of heat from the core to the periphery
7. In patients with blunt head trauma, cerebral perfusion pressure is determined by the gradient between
- (A) diastolic pressure and central venous pressure
 - (B) intracranial pressure and central venous pressure
 - (C) mean arterial pressure and central venous pressure
 - (D) mean arterial pressure and intracranial pressure
 - (E) systolic pressure and intracranial pressure
8. Which of the following muscle relaxants has a prolonged duration of action in a patient who is homozygous for atypical plasma cholinesterase?
- (A) Atracurium
 - (B) Doxacurium
 - (C) Mivacurium
 - (D) Pipecuronium
 - (E) Vecuronium
9. Cholinergic receptor blockade
- (A) decreases intraocular pressure
 - (B) decreases lower esophageal sphincter tone
 - (C) increases gastrointestinal motility
 - (D) induces diaphoresis
 - (E) produces copious secretions
10. A 37-year-old woman with pregnancy-induced hypertension develops oliguria two hours after cesarean delivery during epidural anesthesia. Despite infusion of 2000 mL of crystalloid solution, urine output remains 10 mL/hr. Which of the following laboratory findings is most suggestive of acute tubular necrosis?
- (A) Blood urea nitrogen level of 30 mg/dL
 - (B) Serum creatinine level of 1.2 mg/dL
 - (C) Urinary/plasma osmolality of 1:1
 - (D) Urinary sodium level of 10 mEq/L
 - (E) Urinary specific gravity of 1.024
11. Desflurane at a stable alveolar concentration of 7%
- (A) causes bradycardia
 - (B) decreases cerebrovascular resistance
 - (C) degrades in soda lime
 - (D) increases systemic vascular resistance
 - (E) stimulates the respiratory centers

12. Five minutes after initiating one-lung ventilation using a double-lumen endobronchial tube, a 70-year-old patient has a decrease in SpO₂ from 99% to 90%. Tidal volume and respiratory rate are unchanged. Fiberoptic bronchoscopy verifies appropriate positioning of the tube. Which of the following is the most likely cause of the desaturation?

- (A) Blood flow to the nondependent lung
- (B) Failure of hypoxic pulmonary vasoconstriction in the dependent lung
- (C) Inadequate filling of the bronchial cuff
- (D) Inadequate minute ventilation
- (E) Surgical manipulation of the nondependent lung

13. Which of the following statements regarding innervation of the upper extremity is true?

- (A) Blockade of the radial nerve decreases the patient's ability to spread the fingers apart
- (B) The brachial plexus receives preganglionic sympathetic fibers arising from C5 through T2
- (C) Interscalene injection of the brachial plexus at C6 is likely to spare the axillary nerve
- (D) The musculocutaneous nerves receive contributions from C5 and C6
- (E) The vertebral artery lies posterior to the nerve roots of the brachial plexus

14. A patient undergoes thoracotomy in the lateral decubitus position. Which of the following maneuvers is most likely to increase PaO₂ during one-lung ventilation?

- (A) Applying continuous positive airway pressure to the nondependent lung
- (B) Applying positive end-expiratory pressure to the dependent lung
- (C) Increasing inspiratory flow rate
- (D) Increasing the tidal volume
- (E) Increasing the ventilatory rate

15. Which of the following is the most likely adverse effect of prolonged intravenous administration of nitroglycerin?

- (A) Cyanmethemoglobinemia
- (B) Hemolysis
- (C) Methemoglobinemia
- (D) Neutropenia
- (E) Thrombocytopenia

16. A patient has severe pain after total knee arthroplasty. Systemic opioids are most likely to modify the pain through action at which of the following sites?

- (A) Corpus callosum
- (B) Hippocampus
- (C) Substantia gelatinosa
- (D) Substantia nigra
- (E) Ventral horn of the spinal cord

17. Which of the following is characteristic of the pharmacokinetics of alfentanil?

- (A) Clearance is greater than that of fentanyl
- (B) Elimination half-life is normal in patients with hepatic insufficiency
- (C) Protein binding is minimal
- (D) The majority of alfentanil in plasma is ionized
- (E) Volume of distribution is smaller than that of fentanyl

18. A 55-year-old man undergoes abdominal perineal resection in the lithotomy position during combined epidural (bupivacaine 0.5%) and isoflurane anesthesia. The epidural catheter is left in place with an infusion of fentanyl 50 µg/hr. Twelve hours after surgery, the patient has left footdrop. Which of the following is the most likely explanation?

- (A) Epidural hematoma
- (B) Epidural opioid
- (C) Inadequate padding of the knee during surgery
- (D) Nerve injury from the epidural catheter
- (E) Residual effects of the local anesthetic

19. A 66-year-old woman with essential hypertension has a preoperative blood pressure of 160/95 mmHg despite receiving the usual dose of labetalol on the morning of surgery. Following endotracheal intubation, blood pressure increases to 220/120 mmHg. Which of the following is the most likely explanation?

- (A) Decreased arteriolar compliance
- (B) Increased circulating blood volume
- (C) Increased receptor sensitivity to norepinephrine
- (D) Unopposed beta-adrenergic receptor stimulation
- (E) Upregulation of alpha-adrenergic receptors

20. A 60-year-old man undergoing resection of an abdominal aortic aneurysm has an increase in measured mixed venous oxygen saturation from 70% to 90%. Which of the following is the most likely cause?

- (A) Decreased cardiac output
- (B) Decreased hematocrit
- (C) Intrapulmonary shunting
- (D) Right to left shunting at the atrial level
- (E) Wedging of the pulmonary artery catheter

21. A 55-year-old woman who is scheduled to undergo carotid endarterectomy has a history of essential hypertension and chronic obstructive pulmonary disease. Over a 30-minute period beginning one hour after induction of general anesthesia, SpO₂ decreases from 99% to 95%. During that time, she has received fentanyl 100 µg, isoflurane 1%, nitrous oxide 49.5%, oxygen 49.5%, and a nitroglycerin infusion to maintain blood pressure at approximately 160/95 mmHg. Which of the following is the most likely cause for the decline in oxygen saturation?

- (A) Decreased cardiac output
- (B) Increased dead space ventilation
- (C) Inhibition of hypoxic pulmonary vasoconstriction
- (D) Mainstem intubation
- (E) Second gas effect

22. A 35-kg child requires mechanical ventilation with 100% oxygen at a tidal volume of 350 mL and a rate of 20/min during a severe asthma attack. The most likely cause of severe hypotension after initiating mechanical ventilation is

- (A) hypoxic circulatory depression
- (B) inadequate expiratory time
- (C) increased pulmonary vascular resistance
- (D) respiratory alkalosis
- (E) tension pneumothorax

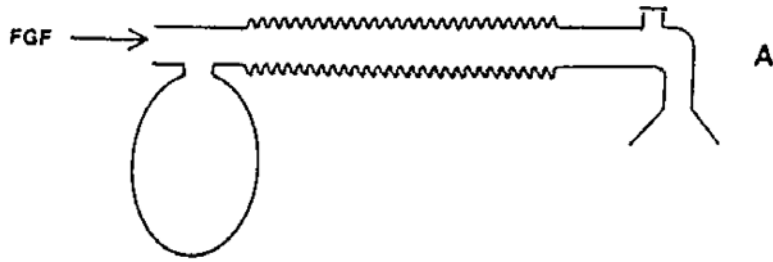

23. The Mapleson A system (Magill circuit) illustrated above
- (A) is functionally equivalent to the Bain circuit
 - (B) prevents rebreathing more effectively during controlled ventilation than during spontaneous ventilation
 - (C) provides better humidification than the Mapleson D system
 - (D) requires a fresh gas flow equal to minute ventilation to prevent rebreathing during spontaneous ventilation
 - (E) results in less rebreathing during controlled ventilation than the Mapleson C system
-
24. In a patient with ventricular fibrillation refractory to repeated attempts at defibrillation and lidocaine administration the most appropriate management is administration of
- (A) bretylium
 - (B) procainamide
 - (C) propranolol
 - (D) quinidine
 - (E) verapamil
25. The flow proportioning system on an anesthesia machine
- (A) is regulated primarily by changes in oxygen input pressure
 - (B) limits nitrous oxide flow when oxygen pressure falls below a preset value
 - (C) maintains a minimum ratio of oxygen to nitrous oxide in fresh gas flow
 - (D) precludes the use of a closed system
 - (E) regulates flows of oxygen and nitrous oxide to maintain a fixed FiO_2
26. Which of the following is the best method of pacing to improve cardiac output in a patient with third-degree heart block?
- (A) VOO
 - (B) AOO
 - (C) VVI
 - (D) DVI
 - (E) Transcutaneous
27. Which of the following is a potentially beneficial effect of ketamine used for induction of anesthesia?
- (A) Analgesia
 - (B) Attenuation of respiratory response to carbon dioxide
 - (C) Decreased cerebral metabolic rate
 - (D) Increased stroke volume in patients with hemorrhagic shock
 - (E) Preservation of laryngeal reflexes

28. A 70-kg 78-year-old man undergoing small-bowel resection during anesthesia with isoflurane in oxygen becomes hypotensive and develops frothy pink sputum in the endotracheal tube. Heart rate is 110 bpm, blood pressure is 75/60 mmHg, pulmonary artery occlusion pressure is 22 mmHg, and cardiac output is 1.7 L/min. The most appropriate initial step in management is administration of which of the following?

- (A) Albumin
- (B) Digoxin
- (C) Dopamine
- (D) Esmolol
- (E) Nitroglycerin

29. One hour after induction of anesthesia for a posterior fossa craniotomy using opioid, relaxant, and nitrous oxide, the brain begins to protrude through the dura. The most effective measure to decrease intracranial pressure is to

- (A) administer additional opioid
- (B) decrease PaCO₂ from 25 to 15 mmHg
- (C) drain cerebrospinal fluid
- (D) discontinue nitrous oxide
- (E) induce hypotension

30. When compared with a healthy 30-year-old man, which of the following respiratory parameters is decreased in an otherwise healthy 80-year-old man?

- (A) Alveolar to arterial oxygen gradient
- (B) Lung compliance
- (C) Ratio of functional residual capacity to total lung capacity
- (D) Resting tidal volume
- (E) Ventilatory response to carbon dioxide

31. A 64-year-old man with diabetes mellitus well controlled with NPH insulin undergoes lower extremity revascularization. Following administration of protamine 10 mg, the patient has facial flushing and blood pressure of 60/30 mmHg. The most appropriate initial step in management is administration of which of the following drugs?

- (A) Diphenhydramine
- (B) Epinephrine
- (C) Hydrocortisone
- (D) Norepinephrine
- (E) Phenylephrine

32. A 26-year-old man who sustained multiple trauma undergoes open reduction and internal fixation of bilateral tibial-fibular fractures during anesthesia with isoflurane, nitrous oxide, and oxygen with positive pressure ventilation. During the procedure, the patient has sudden onset of hypotension, jugular venous distention, deviation of the trachea to the right, and decreased ventilatory compliance. Isoflurane is discontinued and 100% oxygen is administered. Which of the following is the most appropriate next step in management?

- (A) Chest x-ray
- (B) Blood transfusion
- (C) Subxiphoid pericardiocentesis
- (D) Fiberoptic bronchoscopy
- (E) Left chest needle thoracostomy

33. The decreased duration of action of an intravenous dose of fentanyl compared with an intravenous dose of morphine is best explained by
- (A) greater lipid solubility
 - (B) increased hepatic metabolism
 - (C) less protein binding
 - (D) shorter elimination half-life
 - (E) smaller volume of distribution
34. A patient receives methohexital 30 mg just before retrobulbar block with 0.25% bupivacaine 4 mL. Over the next 10 minutes, he develops apnea and loses consciousness. Which of the following is the most likely explanation?
- (A) Effects of methohexital
 - (B) Injection of local anesthetic into cerebrospinal fluid
 - (C) Intravascular injection of local anesthetic
 - (D) Oculocardiac reflex
 - (E) Systemic absorption of local anesthetic
35. Which of the following statements about the standard error of the mean (SE) is true?
- (A) Sample mean \pm SE has approximately a 95% chance of containing the population mean
 - (B) The SE describes the precision of the population mean
 - (C) The SE describes the range of the sample values
 - (D) The SE is greater than the standard deviation
 - (E) The SE is obtained by multiplying the sample standard deviation by the square root of the sample size
36. A 62 year-old woman with polycythemia vera is scheduled to undergo total knee arthroplasty using a tourniquet. Pre-operative hematocrit is 60%. Which of the following is the most appropriate action?
- (A) Perform total knee arthroplasty without use of a tourniquet
 - (B) Preoperative reduction of the hematocrit to 45% to 50%
 - (C) Prophylactic administration of aprotinin during surgery
 - (D) Prophylactic administration of epsilon-aminocaproic acid during surgery
 - (E) Prophylactic administration of low-dose heparin during surgery
37. Left ventricular end-diastolic volume is most likely to be underestimated by pulmonary artery occlusion pressure in patients with
- (A) acute myocardial ischemia
 - (B) aortic insufficiency
 - (C) mitral stenosis
 - (D) primary pulmonary hypertension
 - (E) tricuspid stenosis
38. Immediately following radical prostatectomy, ketorolac administered for analgesia
- (A) aggravates ileus and bladder spasm
 - (B) increases platelet adhesion
 - (C) is ideally suited for patient-controlled analgesia
 - (D) mediates its effects via kappa opioid receptors
 - (E) produces cyclooxygenase inhibition

39. During general anesthesia administered through a circle system, the soda lime absorbant is exhausted. No fresh soda lime is available for use. Which of the following is the most appropriate next step to prevent hypercapnia in this patient?

- (A) Decreasing the dead space of the circle system
- (B) Discontinuing nitrous oxide
- (C) Increasing the fresh gas flow
- (D) Increasing tidal volume
- (E) Switching to spontaneous ventilation

40. A patient undergoes axillary block for placement of an arteriovenous shunt in the forearm. Blockade of the musculocutaneous nerve is not achieved. Injection of a local anesthetic at which of the following sites will provide the required sensory block?

- (A) Between the tendon of the palmaris longus and flexor carpi radialis
- (B) Body of coracobrachialis muscle
- (C) Medial to the brachial artery at the elbow
- (D) Proximal to the medial epicondyle against the medial surface of the humerus
- (E) Superficial to the pulse of the axillary artery

41. A 2.8-kg newborn undergoes repair of a moderate-sized omphalocele. Intravenous fluid is administered at 14 mL/hr. Forty-five minutes after beginning surgery and before reduction of the omphalocele, arterial blood pressure decreases from 80/40 to 55/30 mmHg. SaO₂ is 98% at an FiO₂ of 0.5. Breath sounds are equal bilaterally. Which of the following is the most likely explanation for the decrease in blood pressure?

- (A) Associated congenital cardiac defect
- (B) Compression of the lungs by the abdominal contents
- (C) Inadequate fluid administration
- (D) Pneumothorax
- (E) Sepsis

42. A 40-year-old man who is scheduled to undergo repair of a tendon laceration of the left hand has complete anesthesia in the median, radial, and ulnar nerve distributions after supraclavicular block. Two hours of tourniquet inflation are required for completion of the procedure. The most appropriate next step is an additional block of which of the following?

- (A) Axillary nerve
- (B) Intercostobrachial nerve
- (C) Lateral antebrachial cutaneous nerve
- (D) Musculocutaneous nerve
- (E) Stellate ganglion

43. A patient has hoarseness after undergoing surgery involving the aortic arch. The most likely cause is an injury to which of the following nerves?

- (A) Glossopharyngeal
- (B) Left recurrent laryngeal
- (C) Right recurrent laryngeal
- (D) Left superior laryngeal
- (E) Right superior laryngeal

44. Awakening after a single dose of thiopental is caused by redistribution from the brain primarily to which of the following sites?
- (A) Fat
 - (B) Heart
 - (C) Liver
 - (D) Lung
 - (E) Skeletal muscle
45. A patient undergoes differential spinal block for evaluation of persistent foot pain. If the pain returns coincident with a decrease in skin temperature, which of the following is the most appropriate conclusion?
- (A) A somatic origin is ruled out
 - (B) The patient has causalgia
 - (C) The patient has peripheral vascular disease
 - (D) The pain is caused by central neuropathy
 - (E) Lumbar sympathetic blocks are indicated
46. During general anesthesia with spontaneous ventilation, a patient has a V_D/V_T of 0.5. Which of the following is most likely to decrease the ratio?
- (A) Acute bronchospasm
 - (B) Continuous positive airway pressure
 - (C) Decreased tidal volume
 - (D) Increased cardiac output
 - (E) Pulmonary embolism
47. An unconscious adult patient is being ventilated through an esophageal obturator airway (EOA) in the emergency department. In the absence of cervical spine injury, which of the following is appropriate?
- (A) Use of the EOA for airway management until the patient regains consciousness
 - (B) Removal of the EOA before insertion of an endotracheal tube
 - (C) Placement of an endotracheal tube before removal of the EOA
 - (D) Removal of the EOA under fiberoptic endoscopic visualization
 - (E) Cricothyroidotomy
48. Which of the following detects the smallest volume of venous air embolization?
- (A) Changing the precordial Doppler ultrasound signal
 - (B) Decreasing PETCO₂
 - (C) Decreasing SpO₂
 - (D) Increasing central venous pressure
 - (E) Increasing pulmonary artery pressure
49. Which of the following is the most important factor affecting the incidence of postoperative pulmonary complications?
- (A) Age of the patient
 - (B) Anesthetic technique
 - (C) Duration of surgery
 - (D) Obesity
 - (E) Site of the operation

50. Which of the following remains normal in an otherwise healthy patient with obesity?
- (A) Alveolar PO₂
 - (B) Expiratory reserve volume
 - (C) Functional residual capacity
 - (D) Lung compliance
 - (E) Static lung volumes
51. An obese 70-year-old woman with a long history of tobacco abuse is awake and semirecumbent after uneventful anesthesia with isoflurane for a ventral hernia repair. During the first hour in the recovery room while breathing 50% oxygen by face mask, her SaO₂ decreases to 90% while other vital signs remain satisfactory. Which of the following is most likely to be effective in the management of this situation?
- (A) Intravenous doxapram
 - (B) Racemic epinephrine by inhalation
 - (C) Continuous positive airway pressure by mask
 - (D) Reintubation of the trachea
 - (E) Coughing
52. Three hours after undergoing coronary artery bypass grafting, an elderly man develops severe hypotension after intravenous administration of morphine 4 mg. Pulmonary artery occlusion pressure is 27 mmHg and central venous pressure is 30 mmHg. Transesophageal echocardiography shows decreased end-diastolic ventricular volumes. Which of the following is the most likely diagnosis?
- (A) Anaphylactoid reaction
 - (B) Cardiac tamponade
 - (C) Coronary graft occlusion
 - (D) Excessive fluid administration
 - (E) Pulmonary thromboembolus
53. A 62-year-old man, who had a myocardial infarction three years ago, complicated by congestive heart failure and renal failure, is undergoing a colectomy. A pulmonary artery catheter demonstrates a cardiac output higher than measurements recorded during a cardiac catheterization two months after the infarction. Which of the following most likely contributes to the increased cardiac output?
- (A) Creation of an arteriovenous fistula
 - (B) Increased hemoglobin concentration from 10 to 12 g/dL
 - (C) Stimulation of carotid body receptors
 - (D) Transcutaneous nitroglycerin
 - (E) Use of a beta-adrenergic blocker to prevent myocardial reinfarction
54. Which of the following is characteristic of the airway in a 2-month-old infant when compared with an adult airway?
- (A) Airway is narrowest at the cricoid cartilage
 - (B) Epiglottis is broader
 - (C) Laryngeal mucosa is more tightly adherent
 - (D) Larynx is positioned lower in the neck
 - (E) Vocal cords have a more cephalad anterior attachment

55. A 50-year-old woman has episodes of electric-shock-like pain of one minute in duration affecting the right side of the face. In between episodes of this pain, she is relatively pain free. Which of the following is the most appropriate management?

- (A) Beta-adrenergic blockers
- (B) Carbamazepine
- (C) Infrared heat therapy
- (D) Nonsteroidal anti-inflammatory drugs
- (E) Stellate ganglion block

56. An anesthesia machine is set to deliver oxygen 2 L/min, nitrous oxide 2 L/min, and enflurane. After 30 minutes of stable anesthesia, which of the following is the most likely cause of a decrease in the oxygen analyzer reading from 50% to 30%?

- (A) A leak in the ventilator bellows
- (B) Accumulation of water on the oxygen sensor membrane
- (C) Calibration at 100% oxygen using less than 100% oxygen
- (D) Disconnection of the wall oxygen hose
- (E) Presence of the oxygen analyzer in the expiratory limb

57. A normotensive 66-year-old man undergoes total hip arthroplasty. Mean arterial pressure is maintained at 60 mmHg with isoflurane and labetalol; intraoperative F_{iO_2} is 1.0. Eight units of red blood cells are administered intraoperatively because of an injury to the femoral artery. Five days later, the patient develops jaundice. Which of the following is the most likely cause of the jaundice?

- (A) Delayed hemolysis from transfusion
- (B) Heart failure with hepatic congestion
- (C) Hepatocellular injury from labetalol
- (D) Intraoperative hypotension
- (E) Isoflurane-associated hepatitis

58. A 65-kg 70-year-old man in the PACU is breathing spontaneously at 20/min through an endotracheal tube connected to a T-piece with a fresh gas flow of 5 L/min. He has a tidal volume of 350 mL and an F_{iO_2} of 0.5. SpO_2 decreases from 98% to 84% over one hour, then improves to 92% with an F_{iO_2} of 1.0. Which of the following is the most likely cause of the hypoxemia?

- (A) Decreased functional residual capacity
- (B) Increased dead space ventilation
- (C) Inhibition of hypoxic pulmonary vasoconstriction
- (D) Room air admixture during inspiration
- (E) Shivering

59. During surgery of the forearm under axillary block, a patient has pain in the lateral aspect of the forearm and responds by flexing the elbow. The most likely cause is inadequate block of which of the following nerves?

- (A) Axillary
- (B) Intercostobrachial
- (C) Musculocutaneous
- (D) Radial
- (E) Ulnar

60. Nine months after sustaining an injury to the left forearm, a 30-year-old woman has diffuse, burning pain on the anterior aspect of the forearm and posterior aspect of the hand and discoloration of the skin in the affected areas. The patient should be informed that

- (A) if left untreated, muscle atrophy may develop in the involved limb
- (B) if left untreated, the pain will remain well localized
- (C) physical therapy is not indicated
- (D) the symptoms are directly related to the severity of the initial injury
- (E) the symptoms are most likely secondary to underlying peripheral vascular disease

61. A 50-year-old woman develops stridor 10 hours after undergoing thyroidectomy. The most appropriate management is administration of which of the following drugs?

- (A) Albuterol
- (B) Calcium chloride
- (C) Ipratropium bromide
- (D) Racemic epinephrine
- (E) Triiodothyronine

62. A patient receiving propranolol and nifedipine is scheduled for elective coronary artery bypass surgery. During induction with fentanyl and oxygen, heart rate decreases from 52 to 36 bpm and blood pressure decreases from 130/85 to 80/50 mmHg. Administration of atropine 2 mg intravenously has no effect. The most appropriate treatment at this time is administration of

- (A) epinephrine
- (B) pancuronium
- (C) naloxone
- (D) phenylephrine
- (E) calcium chloride

63. Neurolytic block is most appropriate for

- (A) abdominal pain secondary to hepatic carcinoma
- (B) abdominal pain secondary to chronic pancreatitis
- (C) persistent chest wall pain secondary to intercostal neuralgia following a thoracotomy for trauma
- (D) reflex sympathetic dystrophy of the upper extremity with an excellent but transient response to a series of stellate ganglion blocks with local anesthetic
- (E) a diabetic patient scheduled for surgical sympathectomy to relieve unilateral lower extremity pain secondary to severe peripheral vascular disease

64. A 75-year-old man with aortic stenosis and coronary artery disease has a preinduction heart rate of 68 bpm and blood pressure of 125/70 mmHg. After induction of anesthesia with fentanyl, midazolam, and pancuronium, heart rate is 90 bpm and blood pressure is 85/45 mmHg. ECG shows a new ST-segment elevation in lead II. Which of the following is the most appropriate initial management?

- (A) Ephedrine
- (B) Epinephrine
- (C) Esmolol
- (D) Nitroglycerin
- (E) Phenylephrine

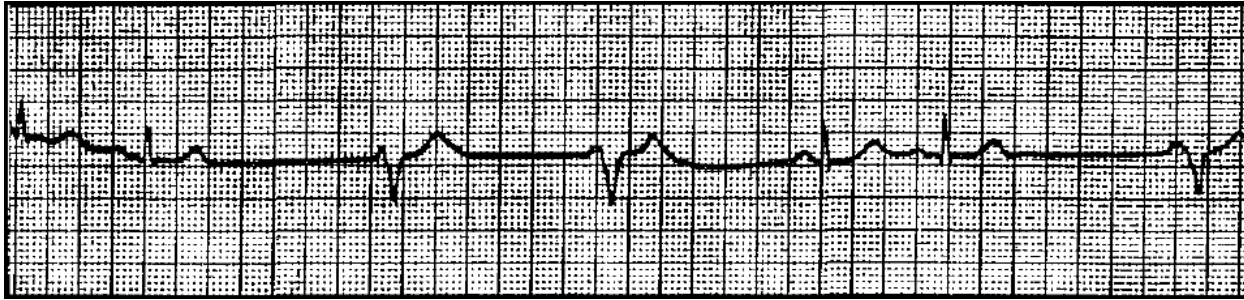

65. The ECG rhythm shown above developed during cholecystectomy in a 62-year-old man who had a myocardial infarction and is taking atenolol. The drug of choice for treating this dysrhythmia is

- (A) atropine
- (B) bretylium
- (C) isoproterenol
- (D) lidocaine
- (E) procainamide

66. An otherwise healthy 70-year-old man receives 12 units of packed red blood cells for persistent diffuse bleeding during suprapubic prostatectomy. Hemoglobin concentration is 11 g/dL, platelet count is 55,000/mm³, plasma fibrinogen concentration is 180 mg/dL, protime is 14 sec, and partial thromboplastin time is 35 sec. The most appropriate therapy is administration of

- (A) cryoprecipitate
- (B) desmopressin (DDAVP)
- (C) epsilon-aminocaproic acid
- (D) fresh frozen plasma
- (E) platelets

67. What is the expected mixed venous oxygen tension, in mmHg, in a normal adult after breathing 100% oxygen for 10 minutes?

- (A) 573
- (B) 563
- (C) 150
- (D) 95
- (E) 45

68. During transurethral resection of the prostate under spinal anesthesia with a sensory level to T10, a patient has sudden onset of sharp upper abdominal pain and nausea. Arterial blood pressure increases from 120/80 to 150/90 mmHg; the patient becomes diaphoretic. Which of the following is the most likely diagnosis?

- (A) Bladder perforation
- (B) Hemolysis
- (C) Hypervolemia
- (D) Hyponatremia
- (E) Myocardial ischemia

69. A 30-year-old woman has an abrupt change from sinus to nodal rhythm with unchanged heart rate on ECG during induction of halothane anesthesia. Which of the following is the most likely result of this change?
- (A) Decreased jugular venous pulsation
 - (B) Decreased mean arterial pressure
 - (C) Decreased systemic vascular resistance
 - (D) Increased cardiac output
 - (E) Increased pulse pressure
70. Which of the following drugs has the shortest elimination half-life?
- (A) Diazepam
 - (B) Flumazenil
 - (C) Flumazepam
 - (D) Lorazepam
 - (E) Midazolam
71. Which of the following findings is characteristic of whole blood preserved in CPD and stored at 4°C for one week?
- (A) Increased potassium concentration
 - (B) Normal concentrations of factors V and VIII
 - (C) PaCO₂ of 40 mmHg
 - (D) pH of 7.3
 - (E) 50% Viable platelets
72. Alveolar and inspired anesthetic concentrations equilibrate more rapidly with nitrous oxide than with desflurane because nitrous oxide
- (A) has a higher vapor pressure
 - (B) has a lower blood gas solubility
 - (C) has a lower MAC
 - (D) is delivered at a higher inspired concentration
 - (E) produces a second gas effect
73. Which of the following complications of caudal anesthesia with 0.25% bupivacaine is more likely in children than in adults?
- (A) Intravascular injection
 - (B) Neurotoxicity
 - (C) Profound motor block
 - (D) Systemic toxicity
 - (E) Total spinal block
74. The primary purpose of denitrogenation prior to anesthetic induction is to
- (A) blunt hypoxic pulmonary vasoconstriction
 - (B) improve ventilation and perfusion matching
 - (C) increase contribution of second gas effect to rate of induction
 - (D) increase oxygen reserve in the functional residual capacity
 - (E) maximize arterial oxygen content

75. Which of the following is the most sensitive indicator of impending renal failure following trauma?
- (A) Central venous pressure
 - (B) Creatinine clearance
 - (C) Fractional excretion of sodium
 - (D) Hourly urine output
 - (E) Urine osmolality
76. A 32-year-old woman sustains an injury to the left recurrent laryngeal nerve during thyroidectomy. Which of the following is the most likely postoperative finding?
- (A) Adduction of the left vocal cord at rest
 - (B) Aphonia
 - (C) Aspiration caused by glottic incompetency
 - (D) Impaired coughing
 - (E) Paralysis of the left cricothyroid muscle
77. Compared with similar use in adults, routine use of succinylcholine in children is hazardous because of the increased risk for which of the following?
- (A) Anaphylactoid reaction
 - (B) Phase II blockade
 - (C) Pseudocholinesterase deficiency
 - (D) Pulmonary aspiration
 - (E) Undiagnosed myopathy
78. The supine hypotensive syndrome of pregnancy
- (A) begins at 32 weeks' gestation
 - (B) causes fetal distress by aortocaval compression
 - (C) is corrected by Trendelenburg's position
 - (D) is less likely following subarachnoid block than epidural block
 - (E) occurs in 90% of supine women at 38 to 40 weeks' gestation
79. In a patient undergoing liver transplantation, sodium bicarbonate and calcium chloride are administered immediately before reperfusion of the transplanted liver to counteract
- (A) coagulopathy
 - (B) decreased cardiac output
 - (C) hyperkalemia
 - (D) hypermagnesemia
 - (E) hypotension
80. Which of the following findings on the left is most likely to be associated with an increased risk of complications with cannulation of the left internal jugular vein compared with cannulation of the right internal jugular vein?
- (A) Longer recurrent laryngeal nerve
 - (B) Lower location of the cupola of the pleura
 - (C) More acute angle between the internal jugular and innominate veins
 - (D) More anterior location of the phrenic nerve
 - (E) Presence of the thoracic duct

81. Desflurane is delivered using a vaporizer that contains internal heaters because
- (A) heat decreases the drug's viscosity
 - (B) heat reduces thermal loss in the patient
 - (C) heat increases the drug's oil: gas partition coefficient
 - (D) heat prevents fluctuations of vapor pressure
 - (E) it does not vaporize adequately at room temperature
82. Which of the following is the most likely effect of administration of magnesium sulfate in a patient with preeclampsia?
- (A) Decreased motor end-plate sensitivity to acetylcholine
 - (B) Decreased uteroplacental blood flow
 - (C) Increased platelet aggregation
 - (D) Increased systemic vascular resistance
 - (E) Inhibited acetylcholinesterase
83. A 65-year-old woman has respiratory distress and loss of consciousness immediately following superficial and deep cervical plexus block for right carotid endarterectomy. Which of the following is the most likely cause?
- (A) Phrenic nerve paralysis
 - (B) Pneumothorax
 - (C) Recurrent laryngeal nerve block
 - (D) Subarachnoid injection
 - (E) Vertebral artery injection
84. During laser microsurgery of the larynx using an endotracheal tube, a fire occurs in the airway. Which of the following is the most appropriate initial management?
- (A) Increase FiO₂ to 1.0
 - (B) Instill saline into the endotracheal tube
 - (C) Perform cricothyroidotomy
 - (D) Remove the endotracheal tube
 - (E) Ventilate with air
85. A 32-year-old man with acute aortic regurgitation is scheduled to undergo emergency aortic valve replacement. Heart rate is 110 bpm, blood pressure is 90/35 mmHg, and pulmonary artery occlusion pressure is 14 mmHg. Cardiac index is 2.2 L/min/m². Which of the following is the most appropriate management?
- (A) Administration of esmolol
 - (B) Administration of a fluid bolus before induction
 - (C) Infusion of dobutamine
 - (D) Infusion of phenylephrine
 - (E) Induction of anesthesia
86. Which of the following drugs administered to a parturient eliminates fetal heart rate variability?
- (A) Atropine
 - (B) Ephedrine
 - (C) Hydralazine
 - (D) Magnesium sulfate
 - (E) Terbutaline

87. During induced hypotension for clipping of a cerebral aneurysm in a 20-degree head-up position, the arterial pressure transducer should be zero referenced at which level?
- (A) External auditory meatus
 - (B) Midaxillary line at the fifth intercostal space
 - (C) Sternal notch
 - (D) Thyroid cartilage
 - (E) Top of the cranium
88. Uterine blood flow is
- (A) autoregulated in normal unanesthetized parturients
 - (B) decreased by the addition of epinephrine 1:200,000 to lidocaine administered epidurally
 - (C) decreased by intravenous infusion of ritodrine in unanesthetized parturients
 - (D) increased by administration of magnesium sulfate to patients with preeclampsia
 - (E) unchanged after paracervical injection of lidocaine without epinephrine
89. Pulse oximetry accurately reflects SaO₂ in which of the following situations?
- (A) Administration of indocyanine green
 - (B) Administration of methylene blue
 - (C) Carboxyhemoglobinemia
 - (D) 40% Fetal hemoglobin concentration
 - (E) Methemoglobinemia
90. Which of the following findings would be considered normal in the EEG of an adult?
- (A) Decreased frequency during induction with halogenated anesthetics
 - (B) Decreased frequency in frontal areas with administration of nitrous oxide 50%
 - (C) Dominance of beta rhythm at 20 to 30 Hz during the awake relaxed state
 - (D) Electrical silence with administration of isoflurane 2.5 MAC
 - (E) The presence of burst suppression during natural sleep
91. A 22-year-old woman at 33 weeks' gestation has abdominal pain and vaginal bleeding after sustaining blunt trauma to the abdomen. Heart rate is 125 bpm, blood pressure is 98/65 mmHg, and respiratory rate is 20/min. Fetal heart rate is 100 bpm. Which of the following is the most appropriate management?
- (A) Conservative observation and monitoring if fetal immaturity is seen on ultrasound
 - (B) Increasing maternal blood pressure with a vasopressor
 - (C) Infusion of terbutaline
 - (D) Lumbar epidural anesthesia
 - (E) Urgent cesarean delivery
92. A patient with a fasting blood glucose concentration of 100 mg/dL undergoes a four-hour operation under general anesthesia without intraoperative administration of glucose. On emergence the most likely finding will be
- (A) marked hypoglycemia
 - (B) mild hypoglycemia
 - (C) normoglycemia
 - (D) mild hyperglycemia
 - (E) marked hyperglycemia

93. Which of the following drugs increases gastric pH while decreasing gastric volume?
- (A) Glycopyrrolate
 - (B) Magnesium trisilicate
 - (C) Metoclopramide
 - (D) Ranitidine
 - (E) Sodium citrate
94. A 72-year-old man has ST-segment depression of 2 mm in ECG lead II immediately after suprarenal aortic clamping. Which of the following is the most likely cause?
- (A) Decreased left ventricular stroke volume
 - (B) Decreased venous return
 - (C) Increased left ventricular wall tension
 - (D) Reflex tachycardia
 - (E) Release of epinephrine from hypoperfused adrenal medulla
95. Which of the following statements concerning neuroleptic malignant syndrome is true?
- (A) It does not respond to dantrolene therapy
 - (B) It is inherited as an autosomal trait
 - (C) It is not triggered by succinylcholine
 - (D) It occurs after long-term use of L-dopa
 - (E) The halothane-caffeine contracture test is negative in susceptible patients
96. Which of the following anesthetic techniques is most appropriate for a woman in the second stage of labor?
- (A) Epidural opioids
 - (B) Local infiltration of the perineum
 - (C) Lumbar sympathetic block
 - (D) Paracervical nerve block
 - (E) Pudendal nerve block
97. Intravenous administration of mannitol during a craniotomy
- (A) decreases intracranial pressure relative to dosage
 - (B) hastens excretion of pancuronium
 - (C) induces metabolic alkalosis
 - (D) produces a sustained increase in intravascular volume
 - (E) requires an intact blood-brain barrier to decrease brain water
98. A 38-year-old woman with B-positive blood requires immediate blood transfusion during abdominal hysterectomy. No B-positive blood is available; O-negative blood is used. Three minutes after starting transfusion of packed red blood cells, the patient develops tachycardia, bronchospasm, and hypotension. Which of the following is the most likely cause?
- (A) Anaphylactic reaction to donor IgA
 - (B) Bacterial contamination of transfused blood
 - (C) Hemolysis resulting from ABO incompatibility
 - (D) Hypocalcemia
 - (E) IgG-mediated reaction to Rh antigens

99. The use of glycine as irrigating solution during transurethral resection of the prostate could be associated with each of the following EXCEPT

- (A) ammonia toxicity
- (B) coma
- (C) hemolysis
- (D) hyponatremia
- (E) transient blindness

100. A 26-year-old man is in the ICU one hour after sustaining a displaced cervical fracture at the level of C7-8 in a diving accident. Each of the following findings is consistent with this patient's injury EXCEPT

- (A) bilateral paralysis of the vocal cord adductors
- (B) gastric dilatation
- (C) hypotension without tachycardia
- (D) inward movement of the chest with inspiration
- (E) normal tidal volume

101. The induction dose of thiopental should be decreased in each of the following situations EXCEPT

- (A) age greater than 70 years
- (B) cardiogenic shock
- (C) decreased hepatic blood flow
- (D) hypoalbuminemia
- (E) hypothyroidism

102. Each of the following conditions is associated with upregulation of the acetylcholine receptor at the neuromuscular junction EXCEPT

- (A) burn injuries
- (B) myasthenia gravis
- (C) prolonged bed rest
- (D) prolonged use of neuromuscular relaxants
- (E) upper motor neuron injury

103. Four days after subarachnoid hemorrhage and surgical clipping of a cerebral aneurysm, a patient develops cerebral artery vasospasm. Appropriate treatment includes each of the following EXCEPT

- (A) administration of nimodipine
- (B) controlled hypertension
- (C) hemodilution to hematocrit of 33%
- (D) hyperventilation to PaCO₂ of 25 to 30 mmHg
- (E) increasing preload

104. Each of the following conditions can be accurately evaluated with transesophageal echocardiography EXCEPT

- (A) intimal tear at the aortic arch
- (B) intracardiac air
- (C) left atrial thrombus
- (D) patent foramen ovale
- (E) right atrial myxoma

105. A patient being mechanically ventilated in the ICU requires wound debridement twice daily. Each of the following agents would be appropriate for induction of brief general anesthesia EXCEPT

- (A) nitrous oxide
- (B) etomidate
- (C) ketamine
- (D) methohexital
- (E) midazolam

106. A 62-year-old patient who is undergoing femoral-popliteal arterial bypass grafting during general anesthesia develops supraventricular tachycardia. Heart rate is 165 bpm and blood pressure is 90/50 mmHg. Which of the following is the LEAST appropriate treatment of the tachycardia?

- (A) Adenosine
- (B) Esmolol
- (C) Phenylephrine
- (D) Procainamide
- (E) Verapamil

107. Which of the following neurophysiologic monitoring modalities is LEAST affected by administration of volatile anesthetic agents?

- (A) Brain stem auditory evoked potentials
- (B) Electroencephalogram
- (C) Motor evoked potentials
- (D) Somatosensory evoked potentials
- (E) Visual evoked potentials

108. A 35-year-old woman with a grade III subarachnoid hemorrhage is undergoing clipping of a middle cerebral artery aneurysm 48 hours after initial hemorrhage. Which of the following drugs used to induce hypotension is LEAST likely to affect intracranial pressure?

- (A) Esmolol
- (B) Hydralazine
- (C) Isoflurane
- (D) Nitroglycerin
- (E) Sodium nitroprusside

109. Which of the following will have the LEAST effect on the shape of the autoregulatory curve for cerebral blood flow?

- (A) Isoflurane
- (B) Nitroprusside
- (C) Hypercarbia
- (D) Essential hypertension
- (E) Cerebral infarction

110. Which of the following treatments is LEAST effective in patients with acute herpes zoster?
- (A) Acyclovir
 - (B) Antidepressants
 - (C) Epidural block
 - (D) Opioids
 - (E) Sympathetic nerve block

DIRECTIONS For each of the questions or incomplete statements below, ONE or MORE of the answers or completions given is correct. On the answer sheet fill in the circle containing

- (A) if only 1, 2, and 3 are correct,
- (B) if only 1 and 3 are correct,
- (C) if only 2 and 4 are correct,
- (D) if only 4 is correct,
- (E) if all are correct.

FOR EACH QUESTION FILL IN ONLY ONE CIRCLE ON YOUR ANSWER SHEET

DIRECTIONS SUMMARIZED

| | | | | |
|---------------|-------------|-------------|-----------|--------------------|
| A | B | C | D | E |
| 1,2,3 only | 1,3 only | 2,4 only | 4 only | All are correct |

111. A 60-kg 70-year-old man who is being mechanically ventilated in the ICU following a left upper lobectomy for bullous emphysema has the following measured parameters:

| | | |
|--------------------------|---------------------------|-----------------|
| BP 100/70 mmHg | HR 104/min (NSR) | |
| PAP 65/34 mmHg | CVP 22 mmHg | CO 3.2 L/min |
| FiO ₂ 0.28 | V _T 0.8 L | f 8 breaths/min |
| PaO ₂ 58 mmHg | PaCO ₂ 48 mmHg | pH 7.28 |

Appropriate initial management to improve this patient's hemodynamic status includes

- (1) increasing FiO₂ to 0.35
- (2) infusion of nitroglycerin
- (3) increasing ventilation rate to 10/min
- (4) administration of dopamine 5 µg/kg/min

112. A 45-year-old man with no history of significant medical problems is scheduled to undergo removal of a brain tumor. Following anesthetic induction, heart rate is 45 bpm (normal sinus rhythm) and blood pressure is 210/120 mmHg. Initial management includes

- (1) ventilation to a PETCO₂ of 25 mmHg
- (2) isoflurane 1%
- (3) elevation of the head of the bed
- (4) intravenous nitroglycerin

113. A 17-year-old boy with muscular dystrophy and scoliosis is scheduled to undergo posterior spinal fusion. Pulmonary function testing using spirometry shows an FEV₁ of 2.4 L (60% of predicted). This abnormality is due to

- (1) restrictive lung disease
- (2) obstructive lung disease
- (3) muscle weakness
- (4) diminished patient effort

FOR EACH QUESTION FILL IN ONLY ONE CIRCLE ON YOUR ANSWER SHEET

DIRECTIONS SUMMARIZED

| | | | | |
|-------|------|------|------|---------|
| A | B | C | D | E |
| 1,2,3 | 1,3 | 2,4 | 4 | All are |
| only | only | only | only | correct |

114. Thermodilution cardiac output is inaccurate in patients with

- (1) aortic stenosis
- (2) ventricular septal defect
- (3) mitral regurgitation
- (4) tricuspid regurgitation

115. Adverse effects of therapeutic doses of tricyclic antidepressants include

- (1) orthostatic hypotension
- (2) prolonged neuromuscular blockade
- (3) tachycardia
- (4) respiratory depression

116. Relative contraindications to administration of thoracic epidural anesthesia include

- (1) bilateral rib fractures
- (2) postherpetic neuralgia at T6
- (3) angina pectoris
- (4) aortic stenosis

117. Clinical situations associated with an increase in parasympathetic activity include

- (1) manipulation of the carotid sinus
- (2) intestinal insufflation during colonoscopy
- (3) traction on the superior oblique muscle during strabismus surgery
- (4) caudal anesthesia for excision of a pilonidal cyst

118. Expected findings in patients with autonomic neuropathy caused by diabetes mellitus include

- (1) increased resting heart rate
- (2) exaggerated hypotension with intravenous induction
- (3) decreased ventilatory response to hypoxia
- (4) decreased gastric motility

119. Appropriate preoperative interventions in a patient scheduled for thoracotomy who has a greater than 100 pack/year history of smoking and a productive cough include

- (1) intermittent positive pressure breathing
- (2) ipratropium
- (3) mucolytic therapy
- (4) incentive spirometry

FOR EACH QUESTION FILL IN ONLY ONE CIRCLE ON YOUR ANSWER SHEET

DIRECTIONS SUMMARIZED

| | | | | |
|-------|------|------|------|---------|
| A | B | C | D | E |
| 1,2,3 | 1,3 | 2,4 | 4 | All are |
| only | only | only | only | correct |

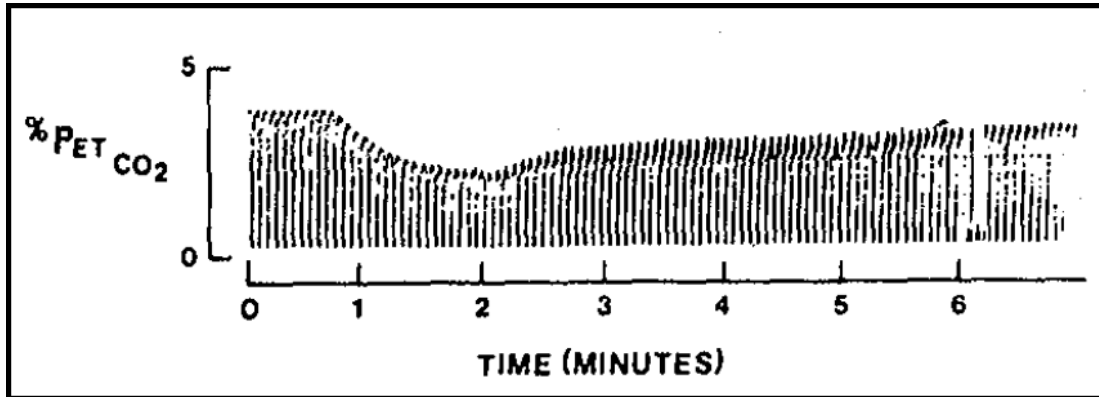

120. The PETCO₂ tracing shown above is consistent with

- (1) an air embolism
- (2) an incompetent expiratory valve
- (3) transient hypovolemia
- (4) a right mainstem bronchial intubation

121. A 38-year-old woman with type I von Willebrand's disease is scheduled to undergo total abdominal hysterectomy. Appropriate preoperative therapy includes administration of

- (1) cryoprecipitate
- (2) desmopressin (DDAVP)
- (3) factor VIII concentrate
- (4) platelets

122. Neuromuscular blocking agents that provide a twitch suppression of greater than 95% and permit spontaneous recovery to baseline of 95% in a maximum of 30 minutes include

- (1) mivacurium
- (2) rocuronium
- (3) succinylcholine
- (4) vecuronium

123. A 65-year-old man with non-insulin-dependent diabetes mellitus is in the recovery room following emergency cholecystectomy. Laboratory studies show a serum glucose concentration of 1000 mg/ dL and a serum sodium concentration of 124 mEq/L. Arterial pH is 7.30. Appropriate management includes administration of

- (1) sodium bicarbonate
- (2) normal saline solution
- (3) furosemide
- (4) regular insulin

FOR EACH QUESTION FILL IN ONLY ONE CIRCLE ON YOUR ANSWER SHEET

DIRECTIONS SUMMARIZED

| | | | | |
|---------------|-------------|-------------|-----------|--------------------|
| A | B | C | D | E |
| 1,2,3 only | 1,3 only | 2,4 only | 4 only | All are correct |

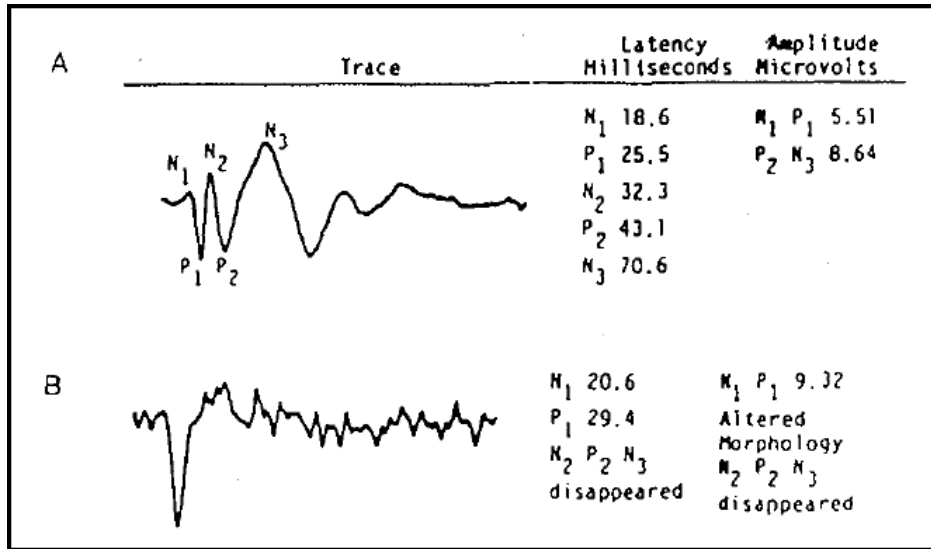

124. The above illustrations represent the change in somatosensory evoked potentials that occurs during carotid endarterectomy. This change is consistent with

- (1) an increase in end-tidal isoflurane concentration from 0.25% to 1.2%
- (2) cerebral ischemia from cross clamping the carotid artery
- (3) a decrease in mean arterial pressure from 100 to 50 mmHg
- (4) an increase in PETCO₂ from 24 to 36 mmHg

125. A patient with moderate aortic stenosis is undergoing transurethral resection of the prostate with spinal anesthesia producing sympathetic block to T6. Expected results of this anesthetic that would adversely affect the aortic stenosis include

- (1) decreased myocardial contractility
- (2) tachycardia
- (3) increased left ventricular preload
- (4) decreased afterload

126. Factors that contribute to microshock include

- (1) failure to use a line isolation monitor
- (2) defective cardiac monitor ground wire
- (3) misapplication of an electrocautery grounding pad
- (4) presence of a central venous catheter

FOR EACH QUESTION FILL IN ONLY ONE CIRCLE ON YOUR ANSWER SHEET

DIRECTIONS SUMMARIZED

| | | | | |
|-------|------|------|------|---------|
| A | B | C | D | E |
| 1,2,3 | 1,3 | 2,4 | 4 | All are |
| only | only | only | only | correct |

127. A 40-year-old woman in the PACU develops dyspnea two hours after thyroid lobectomy with general endotracheal anesthesia. Causes include

- (1) tracheomalacia
- (2) hypocalcemia
- (3) bilateral vocal cord paresis
- (4) paratracheal bleeding

128. True statements concerning apneic oxygenation during bronchoscopy in humans include:

- (1) Denitrogenation is required prior to apnea
- (2) Carbon dioxide accumulation limits acceptable duration
- (3) FRC/body weight ratio influences the rate of decrease of PaO₂
- (4) Moderate hypoxemia develops within six minutes

129. Requirements for obtaining accurate central venous pressure readings include

- (1) zeroing the transducer at the level of the right atrium
- (2) using a pressure transducer system instead of a water manometer
- (3) taking the reading at end-exhalation
- (4) placing the patient in a level horizontal position

130. Appropriate uses of adenosine in the perioperative period include treatment of

- (1) atrial flutter
- (2) atrial fibrillation
- (3) ventricular tachycardia
- (4) paroxysmal supraventricular tachycardia

131. Effects of intraoperative administration of furosemide include

- (1) metabolic acidosis
- (2) decreased risk for acute tubular necrosis
- (3) decreased duration of action of pancuronium
- (4) increased venous capacitance

132. Adverse effects of intravenous ritodrine administered for preterm labor include

- (1) hyperglycemia
- (2) hypokalemia
- (3) tachycardia
- (4) bronchospasm

FOR EACH QUESTION FILL IN ONLY ONE CIRCLE ON YOUR ANSWER SHEET

DIRECTIONS SUMMARIZED

| | | | | |
|-------|------|------|------|---------|
| A | B | C | D | E |
| 1,2,3 | 1,3 | 2,4 | 4 | All are |
| only | only | only | only | correct |

133. A 60-year-old man with alcoholism and cirrhosis undergoes emergency laparotomy. In choosing a dose of thiopental for rapid sequence induction, anesthetic considerations include

- (1) decreased plasma protein binding of thiopental
- (2) decreased total clearance of thiopental
- (3) potential cross-tolerance between barbiturates and alcohol
- (4) increased blood flow to the liver resulting from thiopental

134. Plasma cholinesterase is responsible for the degradation of

- (1) atracurium
- (2) chlorprocaine
- (3) esmolol
- (4) succinylcholine

135. Compared with a normal patient, which of the following is true in a patient with a right-to-left intracardiac shunt?

- (1) Inhalation induction is slowed
- (2) Induction rate for halothane is affected more than that for nitrous oxide
- (3) Intravenous induction is more rapid
- (4) Increased doses of intravenous induction agents are necessary

136. Causes of electromechanical dissociation include

- (1) hypovolemia
- (2) pericardial tamponade
- (3) tension pneumothorax
- (4) venous air embolism

137. Compared with an adult, an infant receiving subarachnoid block with a sensory level to T6 has a

- (1) greater risk for hypotension
- (2) longer duration of block
- (3) greater risk for bradycardia
- (4) larger dose requirement on a mg/kg basis

138. During spontaneous ventilation at ambient pressure, functional residual capacity is decreased by

- (1) supine position
- (2) tracheal intubation
- (3) pregnancy
- (4) general anesthesia

FOR EACH QUESTION FILL IN ONLY ONE CIRCLE ON YOUR ANSWER SHEET

DIRECTIONS SUMMARIZED

| | | | | |
|-------|------|------|------|---------|
| A | B | C | D | E |
| 1,2,3 | 1,3 | 2,4 | 4 | All are |
| only | only | only | only | correct |

139. During isoflurane anesthesia, before surgical incision, systemic vascular resistance decreases following

- (1) a bolus of atracurium 0.5 mg/kg
- (2) euvolemic hemodilution
- (3) administration of vancomycin 1g over a five-minute period
- (4) introduction of nitrous oxide to the anesthetic

140. Following a right thoracotomy, the expected decrease in vital capacity can be attenuated by

- (1) patient-controlled analgesia
- (2) epidural local anesthetics
- (3) epidural opioids
- (4) intercostal nerve blocks

141. Anesthetic considerations in patients undergoing MRI include:

- (1) MRI scan is contraindicated in patients with permanent pacemakers
- (2) The ECG cannot be monitored
- (3) It is safe for the anesthesiologist to remain in the MRI room during the imaging process
- (4) Battery-powered equipment remains operational in the magnetic field

142. Important anatomic landmarks for performing an ankle block include the

- (1) saphenous nerve and the medial malleolus and extensor hallucis longus muscles
- (2) posterior tibial nerve and the lateral malleolus and tendocalcaneus
- (3) deep peroneal nerve and the tendons of the anterior tibial and extensor hallucis longus muscles
- (4) sural nerve and the medial malleolus and tendocalcaneus

143. A 1900-g 3-hour-old infant born at 34 weeks' gestation is scheduled for repair of esophageal atresia with distal tracheoesophageal fistula. Appropriate preoperative evaluation includes

- (1) measurement of serum electrolyte concentrations
- (2) measurement of serum glucose concentration
- (3) cardiac catheterization
- (4) chest x-ray

144. Compared with somatic pain, visceral pain is

- (1) often accompanied by nausea and vomiting
- (2) variable in intensity
- (3) frequently referred to another site
- (4) sympathetically mediated

FOR EACH QUESTION FILL IN ONLY ONE CIRCLE ON YOUR ANSWER SHEET

DIRECTIONS SUMMARIZED

| | | | | |
|-------|------|------|------|---------|
| A | B | C | D | E |
| 1,2,3 | 1,3 | 2,4 | 4 | All are |
| only | only | only | only | correct |

145. Factors that influence the uterine artery to umbilical vein concentration ratio of local anesthetics during epidural anesthesia include

- (1) fetal acidosis
- (2) placental metabolism of the local anesthetic
- (3) maternal plasma protein binding of the local anesthetic
- (4) vasodilator activity of the local anesthetic

146. A patient receiving anesthesia with isoflurane in oxygen has a decrease in SaO₂, from 100% to 85%. Causes include

- (1) endobronchial intubation
- (2) hypoventilation (PaCO₂ = 80 mmHg)
- (3) pneumothorax
- (4) venous air embolism (0.1 mL/kg)

147. Oxidative biotransformation of halothane in a lean, healthy subject results in

- (1) increased serum bromide concentration
- (2) increased serum fluoride concentration
- (3) production of trifluoroacetic acid
- (4) increased serum transaminase concentrations

148. True statements concerning oxygen toxicity in an adult include:

- (1) It is exacerbated by doxorubicin
- (2) It requires greater than 48 hours of exposure
- (3) It includes bone marrow depression
- (4) It does not occur at an FiO₂ less than 0.5

149. Effects of protamine administration for reversal of heparin anticoagulation include

- (1) decreased systemic vascular resistance
- (2) increased pulmonary vascular resistance
- (3) decreased cardiac output
- (4) decreased left atrial pressure

150. Mivacurium

- (1) has a slower onset than succinylcholine
- (2) is hydrolyzed by plasma cholinesterase
- (3) may cause histamine release
- (4) has active metabolites

FOR EACH QUESTION FILL IN ONLY ONE CIRCLE ON YOUR ANSWER SHEET

DIRECTIONS SUMMARIZED

| | | | | |
|-------|------|------|------|---------|
| A | B | C | D | E |
| 1,2,3 | 1,3 | 2,4 | 4 | All are |
| only | only | only | only | correct |

151. A 63-year-old man received atracurium 40 mg intravenously prior to tracheal intubation for a three-hour anesthetic with isoflurane, nitrous oxide, and oxygen. He has a history of chronic renal failure, hypertension treated with nifedipine, and peptic ulcer disease treated with magnesium trisilicate. Neostigmine and atropine were administered at the end of the operation. Causes of persistent weakness in the recovery room include

- (1) decreased atracurium excretion in renal failure
- (2) prolonged paralysis by calcium channel block
- (3) impaired Hofmann elimination by chronic acidosis
- (4) interference with neuromuscular function by hypermagnesemia

152. Two volatile anesthetics are identical except that the blood/gas partition coefficient of anesthetic A is 0.5 and that of anesthetic B is 12. True statements concerning these anesthetics include:

- (1) Emergence from anesthesia will be quicker with anesthetic A than with anesthetic B
- (2) At equilibrium, the partial pressure of anesthetic B in the blood will be 24 times greater than that of anesthetic A
- (3) Hyperventilation will speed induction with anesthetic B more than with anesthetic A
- (4) Circulatory shock during induction will have a greater effect on the alveolar level of anesthetic A than anesthetic B

153. Sympathetic blockade is effective for management of patients with

- (1) reflex sympathetic dystrophy
- (2) early frostbite
- (3) acute supraorbital herpes zoster
- (4) meralgia paresthetica

154. Anatomic boundaries of the epidural space include

- (1) sacral hiatus
- (2) dura mater
- (3) foramen magnum
- (4) anterior longitudinal ligament

155. The successful transition from fetal to neonatal circulation depends on

- (1) decreased systemic vascular resistance
- (2) reversal of flow through the foramen ovale
- (3) increased right ventricular contractility
- (4) decreased pulmonary vascular resistance

FOR EACH QUESTION FILL IN ONLY ONE CIRCLE ON YOUR ANSWER SHEET

DIRECTIONS SUMMARIZED

| | | | | |
|-------|------|------|------|---------|
| A | B | C | D | E |
| 1,2,3 | 1,3 | 2,4 | 4 | All are |
| only | only | only | only | correct |

156. A 15-year-old boy has persistent phantom limb pain one year after below-knee amputation for treatment of an osteogenic sarcoma. Appropriate management includes

- (1) excision of distal neuroma
- (2) administration of carbamazepine (Tegretol)
- (3) femoral nerve block
- (4) administration of amitriptyline

157. Histamine release after morphine administration

- (1) causes dilation of arterioles
- (2) commonly causes bronchospasm
- (3) causes dilation of the venous circulation
- (4) can be prevented by prior administration of H₁ and H₂ antagonists

158. In a patient with myasthenia gravis, cholinergic crisis is characterized by

- (1) bradycardia
- (2) increased salivation
- (3) abdominal cramps
- (4) muscle weakness

159. True statements regarding perioperative potassium homeostasis include:

- (1) Hyperkalemia antagonizes nondepolarizing muscle relaxants
- (2) An infusion of epinephrine increases the serum potassium concentration
- (3) Serum concentration accurately reflects total body potassium
- (4) Decreasing PaCO₂ decreases serum potassium concentration

160. Following lumbar sympathetic block with 6% phenol, neuralgia may develop in the

- (1) genitofemoral nerve
- (2) celiac plexus
- (3) obturator nerve
- (4) pudendal nerve

161. Factors that increase intraocular pressure in a patient with closed-angle glaucoma include

- (1) coughing
- (2) scopolamine
- (3) retrobulbar block
- (4) hypocapnia

FOR EACH QUESTION FILL IN ONLY ONE CIRCLE ON YOUR ANSWER SHEET

DIRECTIONS SUMMARIZED

| | | | | |
|-------|------|------|------|---------|
| A | B | C | D | E |
| 1,2,3 | 1,3 | 2,4 | 4 | All are |
| only | only | only | only | correct |

162. A 9-week-old infant born at 35 weeks' gestation is scheduled to undergo bilateral inguinal hernia repair. Factors that decrease this patient's risk for postoperative apnea include

- (1) volatile anesthesia without opioids
- (2) spinal anesthesia without sedation
- (3) postponing surgery for two weeks
- (4) intraoperative administration of caffeine

163. Maternal adverse effects of beta-tocolytic therapy for preterm labor include

- (1) pulmonary edema
- (2) metabolic acidosis
- (3) ventricular dysrhythmias
- (4) hypoglycemia

164. Mechanical ventilation can increase physiologic dead space by

- (1) increasing airway diameters
- (2) preferentially ventilating nondependent alveoli
- (3) decreasing cardiac output
- (4) increasing pulmonary vascular resistance

165. Acute isovolemic hemodilution increases

- (1) cardiac output
- (2) mixed venous oxygen saturation
- (3) organ blood flow
- (4) serum lactate concentration

166. Carotid body denervation following bilateral carotid endarterectomy may result in

- (1) increased ventilatory response to hypoxia
- (2) minimal increase in resting PaCO₂
- (3) postoperative hypertension
- (4) increased sensitivity to opioid-induced respiratory depression

167. True statements concerning laryngospasm include:

- (1) Laryngeal closure may persist after the stimulus is removed
- (2) The false vocal cords and epiglottis are unaffected
- (3) Superior laryngeal nerve stimulation is primarily responsible
- (4) Laryngeal muscles are relatively insensitive to muscle relaxants

FOR EACH QUESTION FILL IN ONLY ONE CIRCLE ON YOUR ANSWER SHEET

DIRECTIONS SUMMARIZED

| | | | | |
|-------|------|------|------|---------|
| A | B | C | D | E |
| 1,2,3 | 1,3 | 2,4 | 4 | All are |
| only | only | only | only | correct |

168. In a nonanesthetized patient, effects of an acute increase in PaCO₂, to 80 mmHg include

- (1) hyperkalemia
- (2) pulmonary vasoconstriction
- (3) cardiac dysrhythmias
- (4) coronary vasoconstriction

169. Lumbar epidural analgesia administered to a preeclamptic patient during labor and delivery

- (1) facilitates control of maternal blood pressure
- (2) decreases the requirement for magnesium sulfate
- (3) decreases the liberation of adrenal catecholamines
- (4) compensates for the hypervolemia

170. Contraindications for lithotripsy include

- (1) Harrington rod implants
- (2) abdominally placed permanent pacemakers
- (3) obstructive lung disease
- (4) positive pregnancy test

171. Appropriate treatment for accidental injection of thiopental into a radial artery catheter includes injection of which of the following through the catheter?

- (1) Saline
- (2) Lidocaine
- (3) Heparin
- (4) Sodium bicarbonate

172. Three days after undergoing dialysis, a 24-year-old man with chronic renal failure requires revision of the dialysis access site. Findings expected in this patient include

- (1) ECG showing

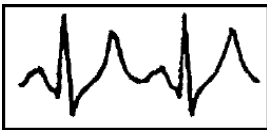

- (2) PaCO₂, of 30 mmHg
- (3) serum bicarbonate concentration of 16 mEq/L
- (4) anion gap of 10 mEq/L

FOR EACH QUESTION FILL IN ONLY ONE CIRCLE ON YOUR ANSWER SHEET

DIRECTIONS SUMMARIZED

| | | | | |
|-------|------|------|------|---------|
| A | B | C | D | E |
| 1,2,3 | 1,3 | 2,4 | 4 | All are |
| only | only | only | only | correct |

173. Appropriate therapy for hypercyanosis ("Tet spell") that develops during anesthesia in an infant with tetralogy of Fallot includes

- (1) propranolol
- (2) dobutamine
- (3) phenylephrine
- (4) ephedrine

174. A 24-year-old patient with hypertension and hypercalcemia is scheduled for a parathyroidectomy. Serum calcium concentration may be decreased by the administration of

- (1) a calcium channel blocker
- (2) magnesium sulfate
- (3) sodium bicarbonate
- (4) vigorous volume expansion

175. During induction of general anesthesia in a patient with a high intestinal obstruction, useful adjuncts for safe induction include

- (1) awake insertion of a laryngeal mask airway
- (2) administration of metoclopramide prior to induction
- (3) administration of an oral antacid
- (4) use of cricoid pressure, even if a nasogastric tube has been left in place

AMERICAN BOARD OF ANESTHESIOLOGY
AMERICAN SOCIETY OF ANESTHESIOLOGISTS

IN-TRAINING EXAMINATION

Book B
1996

PREPARED IN COOPERATION WITH NATIONAL BOARD OF MEDICAL EXAMINERS®

DIRECTIONS: Each of the numbered items or incomplete statements in this section is followed by answers or by completions of the statement. Select the ONE lettered answer or completion that is BEST in each case and fill in the circle containing the corresponding letter on the answer sheet.

1. A patient has a heart rate of 110 bpm one year after heart transplantation. His tachycardia is most likely the result of
 - (A) altered baroreceptor sensitivity
 - (B) cardiac denervation
 - (C) compensation for a fixed stroke volume
 - (D) cyclosporine
 - (E) prednisone

2. An otherwise healthy 20-year-old man undergoes laser surgery for vocal cord polyp removal. During jet ventilation with 100% oxygen, arterial blood gas analysis shows PaO₂ 90 mmHg, PaCO₂ 40 mmHg, and pH_a 7.40. Which of the following is the most likely explanation?
 - (A) Aspiration of gastric contents
 - (B) Atelectasis
 - (C) Pneumothorax
 - (D) Pulmonary embolism
 - (E) Room air entrainment

3. Which of the following findings necessitates the preoperative insertion of a ventricular pacemaker in a 48-year-old man scheduled to undergo cholecystectomy?
 - (A) Atrial flutter with 3:1 atrioventricular block
 - (B) Bifascicular (right bundle branch block and left anterior hemiblock) block
 - (C) Left bundle branch block with first-degree atrioventricular block
 - (D) Second-degree (Mobitz I) atrioventricular block
 - (E) Second-degree (Mobitz II) atrioventricular block

4. A 21-year-old athlete has laryngospasm following extubation after undergoing repair of an inguinal hernia during general anesthesia. Bag and mask ventilation relieves the patient's symptoms. In the PACU 15 minutes later, he has dyspnea; SpO₂ is 85% at an FiO₂ of .40. Which of the following is the most likely cause?
 - (A) Atelectasis
 - (B) Decreased cardiac output
 - (C) Pulmonary edema
 - (D) Pulmonary embolism
 - (E) Residual paralysis

5. Heparin-induced thrombocytopenia
- (A) does not occur with porcine mucosal heparin
 - (B) is caused by direct suppression of platelet production
 - (C) is immunologically mediated
 - (D) is diagnosed by peripheral blood smear
 - (E) occurs only with larger intravenous doses of heparin
6. Which of the following factors will slow the induction of anesthesia in patients receiving volatile anesthetics?
- (A) Addition of 70% nitrous oxide
 - (B) Increased cardiac output
 - (C) Increased minute ventilation
 - (D) Low blood/gas solubility coefficient
 - (E) Previous pneumonectomy
7. A 58-year-old woman with rheumatoid arthritis and hyperactive gag reflex requires awake intubation prior to cervical spine stabilization. Which of the following regional nerve blocks is most appropriate?
- (A) Deep cervical plexus
 - (B) Glossopharyngeal nerve
 - (C) Hypoglossal nerve
 - (D) Superior laryngeal nerve
 - (E) Trigeminal nerve
8. A 120-kg 56-year-old man undergoing gastrectomy during anesthesia with fentanyl and isoflurane has a PETCO₂ of 35 mmHg and a PaCO₂ of 50 mmHg. His FEV₁/FVC ratio is 80% of predicted. Heart rate is 120 bpm and arterial blood pressure is 80/40 mmHg. Which of the following is the most likely cause of the difference in PaCO₂ and PETCO₂?
- (A) Aspiration pneumonitis
 - (B) Chronic obstructive pulmonary disease
 - (C) Decreased cardiac output
 - (D) Decreased V_D/V_T ratio
 - (E) Increased Q_S/Q_T ratio
9. Measurement of blood pressure with a Doppler device involves
- (A) reflection of ultrasound waves off blood elements
 - (B) detection of oscillations in cuff pressure
 - (C) amplification of Korotkoff sounds with a miniature microphone
 - (D) transillumination with a near infrared light
 - (E) detection of variations in blood vessel diameter
10. Which of the following is a sign of cyclosporine toxicity?
- (A) Abnormal hepatic enzyme activity
 - (B) Decreased hemoglobin concentration
 - (C) Increased serum creatinine concentration
 - (D) Nodular density on chest x-ray
 - (E) ST-T-wave changes on ECG

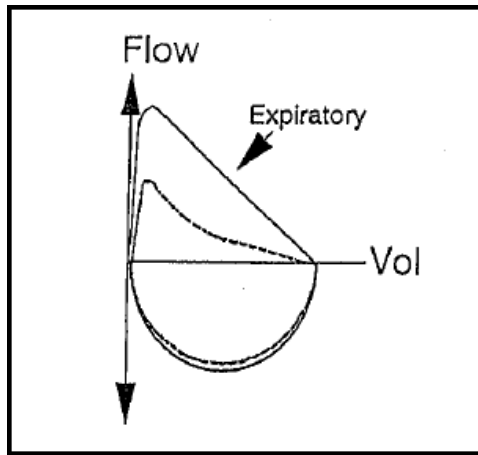

11. The illustration above depicts flow-volume loops for the same person at two different times in his life. Which of the following is indicated by the dotted loop?
- (A) Bronchial tumor
 - (B) Chronic asthmatic bronchitis
 - (C) Morbid obesity
 - (D) Paralysis of a vocal cord
 - (E) Subglottic stenosis
-
12. A healthy 60-kg 52-year-old woman undergoing reduction mammoplasty is anesthetized with isoflurane and oxygen, and deliberate hypotension to 80/40 mmHg is induced with nitroprusside. Urine output through an indwelling urethral catheter has been to 10 mL during the past hour. You should now
- (A) administer furosemide 40 mg intravenously
 - (B) infuse normal saline solution until urine output reaches 35 mL/hr
 - (C) administer dopamine at 3 $\mu\text{g}/\text{kg}/\text{min}$
 - (D) expect normal urine flow with restoration of normal blood pressure
 - (E) discontinue nitroprusside administration
13. Which of the following factors causes a decrease in mixed venous oxygen saturation?
- (A) Arteriovenous fistula
 - (B) Decreased hemoglobin concentration
 - (C) Decreased oxygen consumption
 - (D) Increased cardiac output
 - (E) Nitroprusside toxicity
14. Metoclopramide
- (A) decreases gastric acid secretion
 - (B) decreases gastroesophageal sphincter tone
 - (C) is contraindicated in patients with Parkinson's disease
 - (D) is most effective when administered in combination with atropine
 - (E) requires an intact vagus nerve for gastrointestinal effects

15. Which of the following is the primary factor regulating normal coronary blood flow?
- (A) Aortic diastolic pressure
 - (B) Coronary perfusion pressure
 - (C) Heart rate
 - (D) Myocardial oxygen consumption
 - (E) Systolic wall tension
16. Which of the following is the most common initial sign of hemolytic transfusion reaction during general anesthesia?
- (A) Bronchospasm
 - (B) Diffuse bleeding
 - (C) Fever
 - (D) Hemoglobinuria
 - (E) Hypotension
17. A patient is undergoing exploration of a stab wound to the left side of the neck. On awake laryngoscopy, the left vocal cord is in midposition and the right vocal cord is abducted during inspiration. The most likely cause of these findings is trauma to which of the following structures on the left?
- (A) C7-8 nerve root
 - (B) Stellate ganglion
 - (C) Glossopharyngeal nerve
 - (D) Superior laryngeal nerve
 - (E) Vagus nerve
18. Measurement of which of the following provides the most reliable information about the severity of bronchospasm?
- (A) Diffusing capacity
 - (B) Expiratory reserve volume
 - (C) Forced expiratory volume in 1 second
 - (D) Residual volume
 - (E) Total lung capacity
19. Which of the following provides the most definitive diagnosis in a patient with suspected brain death?
- (A) Absent bilateral somatosensory evoked potentials
 - (B) Absent cerebral blood flow during four-vessel contrast cerebral arteriography
 - (C) Intracranial pressure greater than mean arterial pressure
 - (D) Score of zero on Glasgow Coma Scale
 - (E) Two isoelectric electroencephalograms
20. A woman has weakness of the right quadriceps and a decreased knee jerk reflex on the right one day after forceps delivery under epidural anesthesia. The most likely cause is
- (A) epidural hematoma
 - (B) intrapelvic nerve trauma
 - (C) lithotomy positioning
 - (D) reaction to the preservative in the anesthetic solution
 - (E) trauma from the epidural needle

21. The laryngeal mask airway
- (A) causes more hemodynamic stimulation than an oropharyngeal airway
 - (B) is contraindicated in patients with cervical spine instability
 - (C) is more easily inserted when cricoid pressure is applied
 - (D) may serve as a temporary airway in case of a failed rapid sequence intubation
 - (E) requires administration of a muscle relaxant to avoid laryngospasm during insertion
22. A 45-year-old woman who sustained a subarachnoid hemorrhage 18 hours ago develops a severe headache and becomes unresponsive. Which of the following is the most likely cause of this patient's change in mental status?
- (A) Cerebral edema
 - (B) Cerebral embolism
 - (C) Cerebral vasospasm
 - (D) Hypertensive encephalopathy
 - (E) Second subarachnoid hemorrhage
23. Which of the following statements regarding latex allergy is true?
- (A) Diphenhydramine is the treatment of choice for latex-induced anaphylactic reaction
 - (B) Hospital workers are at equal risk as the general population
 - (C) It is more common in patients with frequent urethral catheterizations
 - (D) Latex gloves can be rinsed free of antigens
 - (E) Skin testing should be performed immediately after an acute reaction in the operating room
24. Neuromuscular blockade of the diaphragm is best ensured by monitoring which of the following peripheral muscles?
- (A) Adductor pollicis muscle
 - (B) First dorsal interosseous muscle
 - (C) Flexor hallucis muscle
 - (D) Muscles of the hypothenar eminence
 - (E) Orbicularis oculi muscle
25. Which of the following statements regarding carbon monoxide poisoning is true?
- (A) Breathing 100% oxygen at 1 atmosphere reduces the carboxyhemoglobin half-life
 - (B) Effective treatment includes administration of methylene blue
 - (C) It is commonly associated with respiratory acidosis
 - (D) It is incompatible with a normal SpO₂ while breathing room air
 - (E) The oxyhemoglobin dissociation curve is shifted to the right
26. In patients with reflex sympathetic dystrophy affecting the arm, which of the following findings indicates a therapeutic block?
- (A) Bradycardia
 - (B) Contralateral nasal congestion
 - (C) Hoarseness
 - (D) Increased skin temperature
 - (E) Ipsilateral Horner's syndrome

27. A 16-year-old patient who sustained trauma is being resuscitated. In deciding whether to infuse lactated Ringer's solution or albumin, which of the following is true?
- (A) At one hour, both will remain in the intravascular compartment to an equal extent
 - (B) Both have zero risk for hepatitis transmission
 - (C) Both will decrease ionized calcium levels
 - (D) The glomerular filtration rate will be higher with infusion of albumin
 - (E) Lactated Ringer's solution causes a greater increase in intracranial pressure
28. Which of the following muscle relaxants is most likely to result in histamine release following administration of a bolus dose sufficient to facilitate rapid endotracheal intubation?
- (A) Atracurium
 - (B) Pancuronium
 - (C) Succinylcholine
 - (D) Rocuronium
 - (E) Vecuronium
29. A 55-year-old man who is scheduled to undergo carotid endarterectomy (CEA) has a persistent myocardial filling defect at three hours on a dipyridamole-thallium scan. Which of the following statements is correct?
- (A) Coronary autoregulation is effective in this segment
 - (B) Coronary revascularization should precede CEA
 - (C) Isoflurane is contraindicated
 - (D) Myocardial infarction is impending
 - (E) There is a segment of nonviable myocardium
30. To measure the contribution of intrapulmonary shunting to arterial hypoxemia, which of the following measurements are necessary? (Assume normal cardiac output and anatomy.)
- (A) PaCO₂ and PECO₂
 - (B) PaCO₂ and PEO₂ while breathing 100% oxygen
 - (C) PaO₂ and PvO₂ while breathing 100% oxygen
 - (D) PaO₂ while breathing both room air and 100% oxygen
 - (E) PaO₂ and PaCO₂ while breathing room air
31. In a patient with severe mitral stenosis, induction of anesthesia must include avoidance of increased
- (A) airway pressure
 - (B) heart rate
 - (C) myocardial contractility
 - (D) right ventricular preload
 - (E) systemic vascular resistance
32. Which of the following is most indicative of reflex sympathetic dystrophy?
- (A) Dry skin
 - (B) Dull pain that improves with movement
 - (C) Fasciculations
 - (D) Motor weakness
 - (E) Pallor and cyanosis

33. During axillary brachial plexus anesthesia, motor block frequently precedes sensory block because of
- (A) conduction velocity of motor fibers
 - (B) myelination of motor fibers
 - (C) size of motor fibers
 - (D) presence of septa between motor fibers
 - (E) peripheral location of motor fibers in the nerve bundle
34. In a patient with chronic renal failure, which of the following statements concerning muscle relaxants is true?
- (A) Duration of action of vecuronium is prolonged
 - (B) The elimination half-life of atracurium is tripled
 - (C) Reversal with neostigmine is contraindicated
 - (D) The onset of action of mivacurium is delayed
 - (E) Succinylcholine is contraindicated
35. Systemic hypothermia to 30°C is accompanied by
- (A) a shift to the right of the oxyhemoglobin dissociation curve
 - (B) a decrease in carbon dioxide dissolved in plasma
 - (C) a decrease in the glomerular filtration rate
 - (D) an increase in MAC of volatile inhalation agents
 - (E) low-voltage, high-frequency EEG pattern
36. After the first 70 minutes of a transurethral resection of the prostate, a 70-year-old man becomes confused and has tachycardia, hypertension, and shortness of breath. Serum sodium concentration is 116 mEq/L. After informing the surgeon that the procedure should be terminated as soon as possible, the most appropriate next step would be to
- (A) administer furosemide
 - (B) administer labetalol
 - (C) administer 3% sodium chloride
 - (D) change the irrigating solution to normal saline
 - (E) induce general endotracheal anesthesia
37. A 30-year-old man who is undergoing laparotomy and resection of a large kidney tumor has a decrease in SpO₂ from 100% to 92% and an increase in peak airway pressure from 20 to 35 cmH₂O. Plateau pressure is unchanged at 18 cmH₂O. Which of the following is the most likely cause?
- (A) Abdominal packing
 - (B) Inadequate anesthesia
 - (C) Inadequate muscle relaxation
 - (D) Obstruction of the endotracheal tube
 - (E) Pneumothorax
38. Gravid uterine blood flow is
- (A) autoregulated
 - (B) decreased by normotensive epidural analgesia
 - (C) decreased by uterine contractions
 - (D) increased with an increase in maternal PaO₂
 - (E) unaffected by alpha-adrenergic agonists

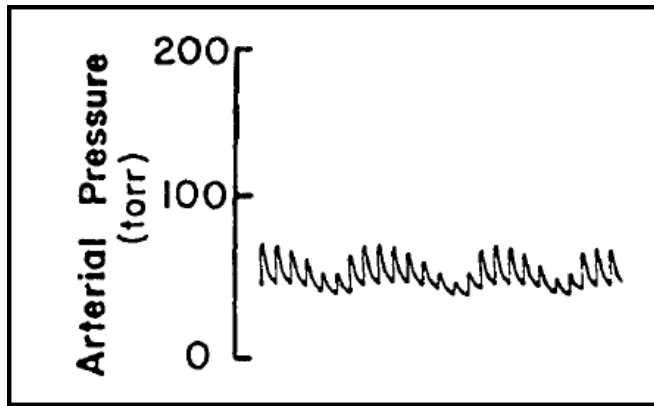

39. A mechanically ventilated newborn infant is undergoing gastroschisis repair during halothane anesthesia. Based on the right radial artery catheter tracing shown above, which of the following is the most appropriate conclusion?

- (A) The abdomen has not yet been incised
- (B) The anesthetic should be changed from halothane to isoflurane
- (C) The ductus arteriosus is still open
- (D) The infant is hypovolemic
- (E) The tidal volume is inadequate

40. A 50-year-old man with alcoholism and jaundice is scheduled to undergo umbilical herniorrhaphy. An increase in which of the following best indicates impaired synthetic hepatic function?

- (A) Prothrombin time
- (B) Serum alanine aminotransferase concentration
- (C) Serum albumin / globulin ratio
- (D) Serum alkaline phosphatase concentration
- (E) Serum bilirubin concentration

41. A patient develops jaundice one week after undergoing laparoscopic cholecystectomy during halothane anesthesia. Laboratory studies show an increased serum alkaline phosphatase concentration, a mildly increased serum aspartate aminotransferase concentration, and a markedly increased conjugated bilirubin fraction. Which of the following is the most likely diagnosis?

- (A) Biliary obstruction
- (B) Gilbert's disease
- (C) Halothane-associated hepatitis
- (D) Hematoma resorption
- (E) Infectious hepatitis

42. Which of the following antihypertensive drugs is most likely to cause bradycardia?

- (A) Captopril
- (B) Clonidine
- (C) Hydralazine
- (D) Nifedipine
- (E) Phenoxybenzamine

43. The two E oxygen cylinders on an anesthesia machine have pressure readings of 1100 psi each. At an oxygen flow of 3 L/min, there will be sufficient oxygen for approximately
- (A) 2.5 hours
 - (B) 3.5 hours
 - (C) 5.5 hours
 - (D) 7 hours
 - (E) 8 hours
44. Which of the following statements concerning use of amitriptyline to treat chronic pain is true?
- (A) It acts primarily via opioid receptors
 - (B) It increases serotonin levels in the brain
 - (C) It is rarely effective for postherpetic neuralgia
 - (D) Onset of action occurs after four to six weeks of treatment
 - (E) Response depends on reversal of depression
45. Nitrous oxide is contraindicated during
- (A) injection of sulfur hexafluoride for retinal tamponade
 - (B) repair of open eye injury
 - (C) scleral buckling with synthetic bands
 - (D) strabismus surgery
 - (E) trabeculectomy for glaucoma
46. Which of the following is the best initial treatment of anaphylaxis that occurs during general anesthesia?
- (A) Diphenhydramine
 - (B) Dopamine
 - (C) Epinephrine
 - (D) Hydrocortisone
 - (E) Ranitidine
47. Which of the following is most likely in a 30-year-old patient with untreated hypothyroidism?
- (A) Cardiac arrhythmias with ketamine administration
 - (B) Decreased ventilatory response to hypoxia
 - (C) Hypoglycemia
 - (D) Increased MAC of inhalational anesthetics
 - (E) Peripheral vasodilatation
48. A 60-year-old man undergoes transurethral resection of a bladder tumor in the lithotomy position with spinal anesthesia. During the procedure the surgeon reports that the patient's right leg is "jumping." This movement is most likely caused by stimulation of which of the following nerves?
- (A) Femoral
 - (B) Lateral femoral cutaneous
 - (C) Obturator
 - (D) Pudendal
 - (E) Sciatic

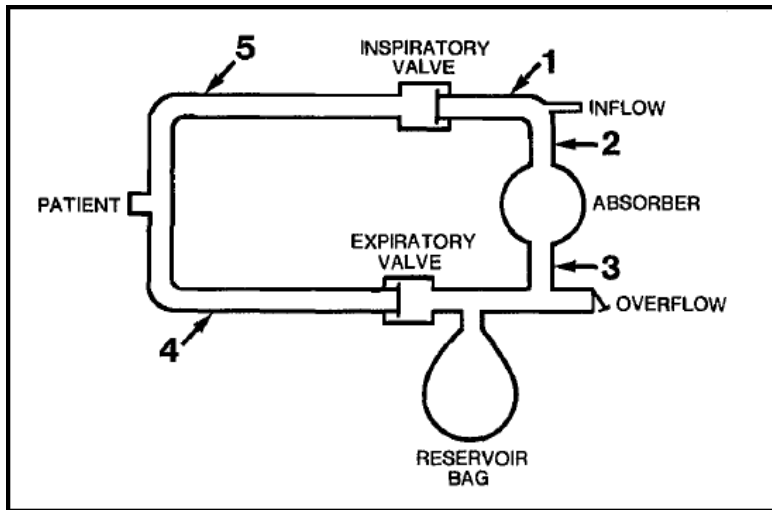

49. To detect the delivery of a hypoxic gas mixture, the optimal location for an oxygen analyzer in this circle is

- (A) 1
- (B) 2
- (C) 3
- (D) 4
- (E) 5

50. Compared with halothane, desflurane has which of the following characteristics?

- (A) Greater potency
- (B) A higher boiling point
- (C) Increased blood solubility
- (D) Less airway irritability
- (E) Less biodegradation

51. Compared with healthy persons, patients with myasthenic (Eaton-Lambert) syndrome have increased

- (A) resistance to vecuronium
- (B) response to neostigmine during reversal of muscle paralysis
- (C) sensitivity to succinylcholine
- (D) susceptibility to development of malignant hyperthermia
- (E) weakness with repetitive activity

52. Pseudocholinesterase

- (A) is increased in patients with myasthenia gravis
- (B) is inhibited by glycopyrrolate
- (C) is inhibited by pilocarpine
- (D) is synthesized by the liver
- (E) reverses atracurium blockade

53. In patients with head trauma, which of the following factors results in a return of arterial pH toward normal levels after two days of mechanical hyperventilation?
- (A) Decreased renal absorption of hydrogen ions
 - (B) Decreased renal blood flow
 - (C) Increased PaCO₂ with constant minute ventilation
 - (D) Increased renal excretion of bicarbonate ions
 - (E) Normalized cerebrospinal fluid pH
54. A 31-year-old man received an uneventful epidural anesthetic for arthroscopy of the knee and meniscectomy. Twenty-four hours later he still has painless flaccid paralysis in both legs. This clinical presentation is most consistent with
- (A) adhesive arachnoiditis
 - (B) anterior spinal artery thrombosis
 - (C) epidural abscess
 - (D) epidural hematoma
 - (E) transverse myelitis
55. Which of the following statements about patient-controlled analgesia using opioids is true?
- (A) It is not associated with respiratory depression
 - (B) It obviates loading doses
 - (C) It requires a background opioid infusion to be effective
 - (D) It requires intravenous administration to be effective
 - (E) It requires less drug than intramuscular dosing for similar analgesia
56. Compared with thiopental, methohexital is characterized by
- (A) better absorption after rectal administration
 - (B) greater protein binding
 - (C) greater hepatic clearance
 - (D) larger volume of distribution
 - (E) more complete biotransformation
57. Pulmonary artery occlusion pressure
- (A) does not reliably reflect left ventricular end-diastolic volume when left ventricular compliance is reduced
 - (B) inaccurately reflects left atrial pressure when left atrial pressure exceeds 15 mmHg
 - (C) is measured at end-inspiration in mechanically ventilated patients
 - (D) overestimates left atrial pressure in patients with poor lung compliance
 - (E) reflects left atrial pressure only if the catheter tip is located in zone II of the lung
58. Which of the following statements regarding fetal heart rate patterns is true?
- (A) Early decelerations suggest umbilical cord compression
 - (B) Fetal heart rates between 160 and 180 bpm are normal
 - (C) Fetal heart rate unaffected by uterine contraction suggests fetal well-being
 - (D) Late decelerations indicate inadequate uteroplacental perfusion
 - (E) Variable decelerations indicate need for urgent delivery

59. A healthy, spontaneously breathing, supine, anesthetized patient has a PaCO₂ to PETCO₂ difference of 3 mmHg. Following institution of mechanical ventilation the value increases to 12 mmHg. The most likely cause of this change is
- (A) cephalad displacement of the diaphragm
 - (B) decreased production of carbon dioxide
 - (C) increased cardiac output
 - (D) increased shunting of blood through dependent lung zones
 - (E) increased ventilation of nondependent lung zones
60. A 34-year-old man has hyperkalemia-induced asystole. After initiating cardiopulmonary resuscitation, which of the following is the most appropriate next step in management?
- (A) Administration of atropine
 - (B) Administration of calcium chloride
 - (C) Administration of sodium bicarbonate
 - (D) Transcutaneous pacing
 - (E) DC countershock at 200 joules
61. A 55-year-old woman receiving chronic dialysis for renal failure comes to the emergency department with a perforated viscus. She has chest pain. Heart rate is 124 bpm, blood pressure is 90/60 mmHg, and respiratory rate is 18/min. Surgery is to be performed within the hour. Which of the following best describes this patient's ASA physical status classification?
- (A) III
 - (B) III E
 - (C) IV
 - (D) IV E
 - (E) V E
62. During isoflurane anesthesia, a 45-year-old patient with chronic asthma has wheezing, prolonged expiration, sinus tachycardia of 120 bpm, and premature ventricular contractions. Preoperative medication included cromolyn and theophylline (serum level 20 µg/mL). The most appropriate treatment is to administer
- (A) albuterol aerosol
 - (B) aminophylline by intravenous infusion
 - (C) cromolyn aerosol
 - (D) halothane
 - (E) hydrocortisone by intravenous bolus
63. Pulmonary artery diastolic pressure increases acutely from 10 to 20 mmHg in a 28-year-old man undergoing cervical laminectomy in the sitting position. The most appropriate first step in the management of this patient is to
- (A) administer furosemide
 - (B) aspirate from the proximal port of the pulmonary artery catheter
 - (C) inflate the balloon on the pulmonary artery catheter
 - (D) place the patient in the left lateral decubitus position
 - (E) start an infusion of nitroglycerin

64. Which of the following would be most likely to increase the duration of seizures during electroconvulsive therapy using a barbiturate and succinylcholine for general anesthesia?
- (A) Administration of atropine prior to therapy
 - (B) Changing to a benzodiazepine for induction
 - (C) Changing to etomidate for induction
 - (D) Adding phenytoin to preoperative medications
 - (E) Decreasing the dose of barbiturate used for induction
65. Compared with isoflurane, desflurane
- (A) causes higher plasma norepinephrine levels
 - (B) has greater biodegradability
 - (C) has a higher blood/gas partition coefficient
 - (D) has a lower MAC value
 - (E) has a lower vapor pressure
66. A celiac plexus block effectively relieves pain at which of the following sites?
- (A) Abdominal viscera above the pelvis
 - (B) Parietal peritoneum above the pelvis
 - (C) Pelvic parietal peritoneum
 - (D) Pelvic viscera
 - (E) Visceral pleura
67. In patients who have undergone cardiopulmonary bypass, administration of milrinone is most likely to result in an increase in which of the following?
- (A) Arterial blood pressure
 - (B) Heart rate
 - (C) Pulmonary capillary wedge pressure
 - (D) Stroke volume
 - (E) Systemic vascular resistance
68. Which of the following is associated with the application of a transdermal fentanyl patch?
- (A) Achievement of a peak plasma level within one hour
 - (B) Continued uptake after patch removal
 - (C) Dose-independent plasma clearance
 - (D) Tachyphylaxis when used for cancer pain
 - (E) Naloxone-resistant toxicity
69. The MAC of a volatile anesthetic agent is greatest when administered to which of the following groups of healthy patients?
- (A) Neonates
 - (B) Infants
 - (C) Adolescents
 - (D) Men 30 years of age
 - (E) Parturients

70. Which of the following statements concerning cerebral vasospasm following intracranial hemorrhage is true?
- (A) It is accompanied by paradoxical intracranial hypotension
 - (B) It responds to nitroprusside therapy
 - (C) It persists more than 48 hours after hemorrhage
 - (D) It is exacerbated by intravascular volume expansion
 - (E) It is confirmed by ST-T-wave changes in the absence of myocardial ischemia
71. Which of the following inhalational anesthetics best relieves left ventricular outflow obstruction in a patient with hypertrophic obstructive cardiomyopathy (IHSS)?
- (A) Desflurane
 - (B) Halothane
 - (C) Isoflurane
 - (D) Nitrous oxide
 - (E) Sevoflurane
72. The metabolism of which of the following hypotensive agents is most likely to be affected in patients with severe renal disease?
- (A) Esmolol
 - (B) Hydralazine
 - (C) Nitroglycerin
 - (D) Nitroprusside
 - (E) Trimethaphan
73. In a 45-year-old patient with severe mitral regurgitation, which of the following is the most important hemodynamic condition to avoid during induction of anesthesia?
- (A) Decreased heart rate to less than 60 bpm
 - (B) Increased heart rate to greater than 90 bpm
 - (C) Increased preload
 - (D) Increased afterload
 - (E) Enhanced myocardial contractility
74. Delirium produced by high doses of atropine can be reversed by intravenous injection of
- (A) diphenhydramine
 - (B) flumazenil
 - (C) naloxone
 - (D) neostigmine
 - (E) physostigmine
75. Which of the following statements best describes testing for susceptibility to malignant hyperthermia (MH)?
- (A) Live skeletal muscle cells are required for testing
 - (B) The MH gene is located on the X chromosome
 - (C) Muscle biopsy is appropriate in children younger than 1 year
 - (D) A normal serum creatine phosphokinase concentration eliminates the need for muscle biopsy
 - (E) Succinylcholine is used to stimulate muscle obtained on biopsy for MH

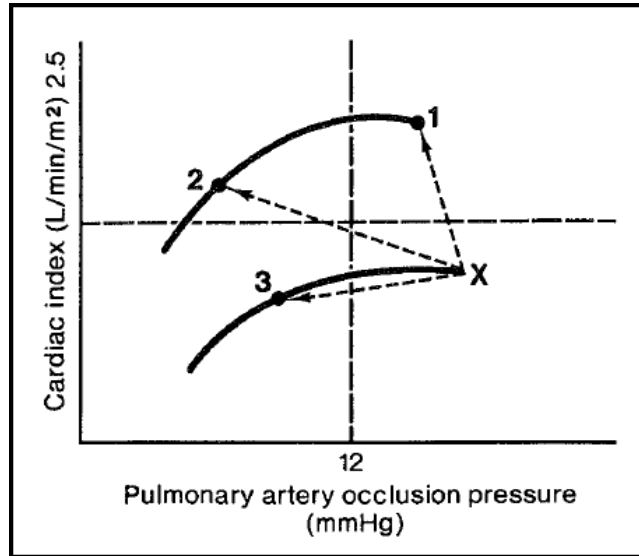

76. In the diagram above, point "X" represents a patient with severe left ventricular dysfunction. The points labeled 1, 2 and 3 each represent the results of a different therapeutic intervention. Which of the following represents the most likely intervention at each point?

| <u>Point 1</u> | <u>Point 2</u> | <u>Point 3</u> |
|-------------------|----------------|----------------|
| (A) Dopamine | Furosemide | Nitroprusside |
| (B) Dopamine | Nitroprusside | Furosemide |
| (C) Furosemide | Dopamine | Nitroprusside |
| (D) Nitroprusside | Dopamine | Furosemide |
| (E) Nitroprusside | Furosemide | Dopamine |

77. A 30-kg patient with asthma is receiving general anesthesia and being mechanically ventilated with a measured tidal volume of 300 mL. Increasing the fresh gas flow from 3 L/min to 9 L/min without changing the ventilatory rate or I:E ratio will result in

- (A) decreased physiologic dead space
- (B) increased delivered tidal volume
- (C) increased end-expired carbon dioxide
- (D) unchanged delivered minute volume
- (E) unchanged peak inspiratory pressure

78. A 30-year-old man who is breathing spontaneously has a ventilatory pattern of sustained deep inspiration and occasional expiratory gasps during emergence from general anesthesia after posterior fossa craniotomy. Which of the following is the most likely cause?

- (A) Air in the cerebral ventricles
- (B) Expiratory obstruction from subglottic edema
- (C) Injury to the C3-5 nerve roots
- (D) Injury to the pons
- (E) Residual neuromuscular paralysis

79. Which of the following findings is most likely in an 85-kg 30-year-old man who is breathing spontaneously through a 6-mm endotracheal tube?
- (A) Decreased PETCO₂
 - (B) Decreased SpO₂
 - (C) Increased minute ventilation
 - (D) Increased respiratory rate
 - (E) Increased tidal volume
80. Which of the following findings best indicates complete resolution of spinal anesthesia?
- (A) Ability to ambulate
 - (B) Ability to urinate
 - (C) Perianal pinprick sensation
 - (D) Pain at the surgical site
 - (E) Proprioception of the big toe
81. After the bronchial and tracheal cuffs of a right endobronchial tube are inflated, ventilation through the tracheal side is not possible. This finding is most consistent with
- (A) cuff occlusion of the right upper lobe bronchus
 - (B) intubation of the left bronchus
 - (C) left-sided tension pneumothorax
 - (D) overinflation of the bronchial cuff
 - (E) positioning of both cuffs in the trachea
82. Which of the following statements concerning the management of diabetes mellitus during pregnancy is true?
- (A) Insulin requirements remain essentially unchanged during pregnancy
 - (B) Maternal blood glucose concentration of 200 mg/dL is optimal
 - (C) Maternal hyperglycemia may cause neonatal acidosis
 - (D) Neonatal hyperglycemia is common
 - (E) Infants delivered under general anesthesia have lower Apgar scores than those delivered under spinal anesthesia
83. Local anesthetics block nerve impulses through which of the following mechanisms of action?
- (A) Decreasing ATP in neuronal cell membranes
 - (B) Decreasing the neuronal resting membrane potential
 - (C) Increasing extracellular calcium concentration
 - (D) Inhibiting sodium ion influx across the neuronal cell membrane
 - (E) Opening sodium channels at the nodes of Ranvier
84. While delivering nitrous oxide 1.5 L/min, oxygen 1.5 L/min, and halothane 1%, a leak in the oxygen flowmeter will most likely be detected by the
- (A) low airway pressure alarm
 - (B) "fail-safe" system
 - (C) oxygen analyzer on the expiratory limb
 - (D) oxygen flowmeter reading
 - (E) mass spectrometric analysis of gases

85. Which of the following is the most appropriate initial therapy for acute pulmonary hypertension with right ventricular dysfunction and severe systemic hypotension that occurs during anesthesia?
- (A) Amrinone
 - (B) Epinephrine
 - (C) Isoflurane
 - (D) Isoproterenol
 - (E) Nitroglycerin
86. An adult patient with atrial fibrillation develops pulseless ventricular tachycardia while undergoing synchronized electrical cardioversion. Which of the following is the most appropriate management?
- (A) Intravenous administration of adenosine
 - (B) Intravenous administration of a bolus of lidocaine followed by electrical cardioversion
 - (C) Immediate repeat synchronized cardioversion at the same energy level
 - (D) Immediate repeat synchronized cardioversion at twice the previous energy level
 - (E) Unsynchronized electrical cardioversion
87. In an infant, spinal anesthesia to a sensory level of T8 is achieved with tetracaine administered at the L2-3 interspace. Compared with spinal anesthesia to the same sensory level in an adult, this anesthetic is associated with a
- (A) greater decrease in blood pressure
 - (B) higher risk for neurotoxicity
 - (C) higher risk for systemic toxicity
 - (D) lower risk for spinal cord injury
 - (E) shorter duration of action
88. Fentanyl-induced bradycardia is
- (A) independent of the speed of injection
 - (B) independent of dose
 - (C) caused by direct inhibition of adrenal catecholamine release
 - (D) caused by vagal stimulation
 - (E) caused by direct SA node depression
89. Which surface area of the upper extremity is most likely to be unanesthetized by an interscalene brachial plexus block?
- (A) Hypothenar eminence
 - (B) Thenar eminence
 - (C) Dorsolateral surface of the hand
 - (D) Lateral aspect of the forearm
 - (E) Lateral surface of the upper arm
90. An enflurane vaporizer is filled with halothane and the vaporizer dial is set at 1%. Which of the following will occur?
- (A) Less than 1% halothane will be delivered
 - (B) More than 1% halothane will be delivered
 - (C) Thymol precipitation will prevent vaporization
 - (D) The vaporizer bypass will not open
 - (E) The vaporizer will be damaged

91. During an inguinal hernia repair, a newborn infant will have a larger fluid requirement (in milliliters per kilogram) than an adult because of relatively greater
- (A) insensible water loss
 - (B) lean body mass
 - (C) metabolic rate
 - (D) sodium loss
 - (E) third space losses
92. In a healthy 70-kg adult, which of the following is the most likely effect of intravenous administration of morphine 10 mg on ventilatory responses?
- (A) Increased response to hypoxia and decreased response to hypercarbia
 - (B) Decreased response to hypercarbia and no change in response to hypoxia
 - (C) Decreased response to both hypoxia and hypercarbia
 - (D) No change in response to hypercarbia and decreased response to hypoxia
 - (E) No change in response to hypoxia or hypercarbia
93. Which of the following features is characteristic of the airway in a neonate?
- (A) Glottis that is located at the level of the C6 vertebral body
 - (B) Larger tongue relative to the head than in an adult
 - (C) Laryngeal mucosa that is densely adherent to the cartilages
 - (D) More posterior glottis than that of an adult
 - (E) Narrowest portion of the airway that is located at the arytenoid cartilages
94. During induction of anesthesia for cesarean delivery, pancuronium is inadvertently substituted for succinylcholine. The neonate shows no clinical signs of muscle relaxation because pancuronium is
- (A) highly ionized
 - (B) highly protein bound
 - (C) a large molecule
 - (D) lipid soluble
 - (E) unaffected by "ion trapping"
95. Which of the following is the most appropriate initial management of a patient with hypotension secondary to sepsis?
- (A) Calcium chloride
 - (B) Corticosteroids
 - (C) Crystalloid infusion
 - (D) Dopamine
 - (E) Fresh frozen plasma
96. The alveolar concentrations of anesthetics increase more rapidly in children than in adults because of a greater
- (A) blood volume (per kg body mass)
 - (B) cardiac index
 - (C) MAC
 - (D) ratio of alveolar ventilation to functional residual capacity
 - (E) tidal volume (per kg body mass)

97. A 70-kg 58-year-old man with unstable angina is scheduled to undergo coronary artery bypass grafting. Intravenous heparin and nitroglycerin are administered for four days before surgery. Before initiating cardiopulmonary bypass, 21,000 units of heparin are administered through the central venous catheter; five minutes later, activated clotting time is 280 seconds. Which of the following is the most appropriate next step in management?
- (A) Discontinue nitroglycerin
 - (B) Administer additional heparin
 - (C) Administer cryoprecipitate
 - (D) Administer fresh frozen plasma
 - (E) Initiate cardiopulmonary bypass
98. A 30-year-old man receives spinal anesthesia to the level of T4. Ten minutes later, heart rate and blood pressure abruptly decrease to 30 bpm and 60/25 mmHg, respectively. The most appropriate management is administration of which of the following drugs?
- (A) Atropine
 - (B) Epinephrine
 - (C) Isoproterenol
 - (D) Metaraminol
 - (E) Phenylephrine
99. An infant is delivered by forceps following labor in which variable decelerations were noted. Amniotic fluid was clear. Initial evaluation shows a cyanotic, limp infant with a heart rate of 80 bpm, poor respiratory efforts, and grimacing in response to suctioning. The most appropriate method of resuscitation for this newborn is
- (A) vigorous tactile stimulation
 - (B) bag and mask ventilation with oxygen
 - (C) immediate endotracheal intubation
 - (D) administration of sodium bicarbonate 1 mEq/kg
 - (E) volume expansion with normal saline solution 10 mL/kg
100. A 57-year-old man has back pain, a heart rate of 90 bpm, decreased pulse in the left arm, and blood pressure of 200/110 mmHg. During infusion of nitroprusside, heart rate increases to 115 bpm and blood pressure decreases to 140/80 mmHg. The most appropriate management at this time is administration of
- (A) droperidol
 - (B) nifedipine
 - (C) normal saline solution
 - (D) propranolol
 - (E) verapamil
101. A multigravid woman is receiving oxytocin by infusion for augmentation of labor. Fetal heart rate is 190 bpm with beat-to-beat variability of 6 to 8 bpm. The most appropriate immediate action would be to
- (A) continue observation
 - (B) sample fetal scalp blood
 - (C) discontinue oxytocin
 - (D) administer a beta-adrenergic blocker to the mother
 - (E) deliver the fetus

102. A patient who is scheduled for emergency debridement of an infected wound on the sole has trismus, rigidity of facial muscles, and spasms of the intercostal muscles, diaphragm, and extremities. During anesthesia, this patient is at increased risk for each of the following EXCEPT

- (A) hypotension
- (B) hypertension
- (C) tachycardia
- (D) diaphoresis
- (E) hypothermia

103. A 30-year-old man has had burning pain, allodynia, and edema of the hand for six weeks after sustaining a forearm fracture. Appropriate treatment includes each of the following EXCEPT

- (A) physical therapy, employing stress loading
- (B) oral prazosin
- (C) intravenous regional sympathetic block with guanethidine
- (D) stellate ganglion block with 6% phenol
- (E) transcutaneous electrical nerve stimulation

104. Each of the following is a complication or side effect of neurolytic celiac plexus blockade EXCEPT

- (A) constipation
- (B) hematuria
- (C) orthostatic hypotension
- (D) paraplegia
- (E) pneumothorax

105. Fresh frozen plasma is indicated in each of the following situations EXCEPT

- (A) after rapid transfusion of 1.5 L CPD-stored red blood cells
- (B) antithrombin III deficiency
- (C) replacement of factor VIII
- (D) reversal of warfarin effect
- (E) thrombotic thrombocytopenic purpura

106. Monitoring sensory evoked potentials may be useful in detecting functional derangement of each of the following EXCEPT

- (A) cranial nerve pathways during posterior fossa operations
- (B) motor pathways during anterior cervical discectomy
- (C) dorsal column pathways during operations for spinal tumors
- (D) visual pathways during operations on the sphenoid wing
- (E) cortical pathways during carotid artery operations

107. Which of the following is the LEAST likely cause of a prolonged prothrombin time?

- (A) Chronic warfarin therapy
- (B) Disseminated intravascular coagulation
- (C) Hemophilia A
- (D) Systemic heparinization
- (E) Vitamin K deficiency

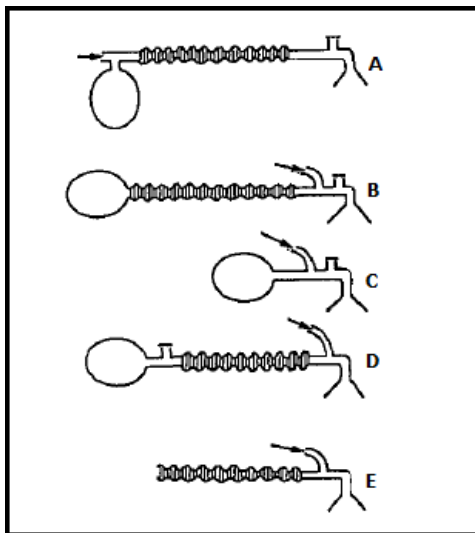

108. Which Mapleson breathing circuit shown in the illustration above permits the LEAST amount of fresh gas inflow to prevent rebreathing during spontaneous ventilation?

- (A) A
- (B) B
- (C) C
- (D) D
- (E) E

109. A 6-year-old boy undergoes craniotomy in the supine position for brain tumor during anesthesia with 1.5% isoflurane in oxygen. PETCO₂ is 38 mmHg, heart rate is 78 bpm, and blood pressure is 130/80 mmHg. After opening the dura, the surgeon notes that the brain is bulging. Which of the following management options is LEAST likely to significantly decrease brain size?

- (A) Decreased isoflurane concentration
- (B) Furosemide
- (C) Hyperventilation to a PaCO₂ of 25 mmHg
- (D) Mannitol
- (E) Nitroprusside

110. A 58-year-old man undergoes repeat coronary artery bypass grafting. Which of the following is LEAST likely to decrease the need for exogenous blood transfusion?

- (A) Cell saver blood collection before and after cardiopulmonary bypass
- (B) Epsilon-aminocaproic acid administered during cardiopulmonary bypass
- (C) High-dose aprotinin administered during cardiopulmonary bypass
- (D) Tranexamic acid infusion during cardiopulmonary bypass
- (E) Desmopressin administered after cardiopulmonary bypass

DIRECTIONS For each of the questions or incomplete statements below, ONE or MORE of the answers or completions given is correct. On the answer sheet fill in the circle containing

- (A) if only 1, 2, and 3 are correct,
- (B) if only 1 and 3 are correct,
- (C) if only 2 and 4 are correct,
- (D) if only 4 is correct,
- (E) if all are correct.

FOR EACH QUESTION FILL IN ONLY ONE CIRCLE ON YOUR ANSWER SHEET

DIRECTIONS SUMMARIZED

| | | | | |
|-----------------|--------------|--------------|-----------|--------------------|
| A | B | C | D | E |
| 1, 2, 3 only | 1, 3 only | 2, 4 only | 4 only | All are correct |

111. Four hours ago, a 3 year-old child aspirated a peanut that partially occludes the right mainstem bronchus. Which of the following findings would be expected?

- (1) Expiratory wheezing
- (2) Inspiratory stridor
- (3) Hyperlucency of the involved lung
- (4) Hypercarbia

112. A 64-year-old man who takes levodopa for management of Parkinson's disease is scheduled to undergo total hip arthroplasty. Appropriate management includes

- (1) metoclopramide for reduction of gastric volume
- (2) omission of levodopa on the morning of surgery
- (3) droperidol for antiemesis
- (4) propofol for induction of anesthesia

113. Conditions requiring emergency surgical intervention in infants include

- (1) necrotizing enterocolitis with perforation
- (2) duodenal atresia
- (3) gastroschisis
- (4) pyloric stenosis

114. A patient recovers from neuromuscular blockade approximately 20 minutes after the administration of succinylcholine 1 mg/kg. This finding is consistent with

- (1) term pregnancy
- (2) prior administration of echothiophate
- (3) a dibucaine number of 60 and a fluoride number of 45
- (4) homozygous atypical pseudocholinesterase

FOR EACH ITEM FILL IN ONLY ONE CIRCLE ON YOUR ANSWER SHEET

DIRECTIONS SUMMARIZED

| | | | | |
|-----------------|--------------|--------------|-----------|--------------------|
| A | B | C | D | E |
| 1, 2, 3 only | 1, 3 only | 2, 4 only | 4 only | All are correct |

115. Relative contraindications to transesophageal echocardiography include

- (1) esophageal varices
- (2) Zenker's diverticulum
- (3) esophageal stricture
- (4) hiatal hernia

116. During posterior craniotomy in the sitting position for removal of an arteriovenous malformation, venous air entry is detected and is aspirated via a right atrial catheter. One hour after surgery, the patient remains unresponsive. Causes include

- (1) residual neuromuscular blockade
- (2) tension pneumocephalus
- (3) brain stem hemorrhage
- (4) air embolism through a patent foramen ovale

117. Apnea results in a more rapid decrease in PaO_2 in pregnant patients at term than in nonpregnant patients. This rapid hypoxia is caused by

- (1) increased oxygen consumption
- (2) increased cardiac output
- (3) decreased functional residual capacity
- (4) increased alveolar-arterial oxygen tension difference

118. Anatomic landmarks for sciatic nerve block in the lateral position include the

- (1) greater trochanter of the femur
- (2) tip of the coccyx
- (3) posterior superior iliac spine
- (4) ischial tuberosity

119. A 70-kg normothermic patient is being mechanically ventilated with a tidal volume of 1000 mL and a respiratory rate of 14/min. The spirometer of the anesthesia machine indicates an exhaled tidal volume of 1000 mL. Peak airway pressure is 45 cmH_2O , plateau airway pressure is 18 cmH_2O , and I:E ratio is 1:3. Arterial blood gases are PaO_2 110 mmHg, PaCO_2 39 mmHg, and pH 7.40 at an FiO_2 of 50%. True statements concerning this patient include:

- (1) Physiologic dead space is decreased
- (2) Changing the I:E ratio to 1:2 will increase the peak airway pressure
- (3) Changing the I:E ratio to 1:1 will increase the plateau pressure
- (4) Static lung compliance is normal

FOR EACH QUESTION FILL IN ONLY ONE CIRCLE ON YOUR ANSWER SHEET

DIRECTIONS SUMMARIZED

| | | | | |
|-----------------|--------------|--------------|-----------|--------------------|
| A | B | C | D | E |
| 1, 2, 3 only | 1, 3 only | 2, 4 only | 4 only | All are correct |

120. A 16-year-old patient with diabetes mellitus requires exploratory laparotomy for probable rupture of the appendix. The patient is unconscious. Serum sodium concentration is 126 mEq/L, potassium is 4.9 mEq/L, glucose is 740 mg/dL, and BUN is 50 mg/dL. Urinary output is 120 mL/hr. Arterial blood gas analysis while breathing room air shows PaO₂ 96 mmHg, PaCO₂ 22 mmHg, and pH 7.08. Preanesthetic management should include

- (1) administration of regular insulin intravenously
- (2) rapid infusion of 0.9% sodium chloride
- (3) correction of acidemia with sodium bicarbonate
- (4) administration of potassium intravenously

121. A woman in the second trimester of pregnancy undergoes emergency appendectomy. Use of isoflurane is expected to

- (1) anesthetize the fetus
- (2) increase the risk for fetal limb defects
- (3) decrease the beat-to-beat variability of fetal heart rate
- (4) increase maternal uterine muscle tone

122. Factors that provide intraoperative cerebral protection during temporary occlusion of the middle cerebral artery include

- (1) systemic hypertension
- (2) mild hypothermia
- (3) thiopental-induced EEG burst suppression
- (4) hyperventilation

123. A 63-year-old man requires mechanical ventilation for three days after an automobile accident. Causes of an increased gradient between this patient's PaCO₂ and PETCO₂ include

- (1) right upper lobe collapse
- (2) decreased cardiac output
- (3) lengthening of the ventilator circuit
- (4) pulmonary embolus

124. Anesthetic considerations in a patient with severe chronic cirrhosis include

- (1) increased volume of distribution for thiopental
- (2) increased risk for halothane-induced hepatic necrosis
- (3) decreased plasma pseudocholinesterase concentration
- (4) increased arteriovenous oxygen tension difference

FOR EACH QUESTION FILL IN ONLY ONE CIRCLE ON YOUR ANSWER SHEET

DIRECTIONS SUMMARIZED

| | | | | |
|-----------------|--------------|--------------|-----------|--------------------|
| A | B | C | D | E |
| 1, 2, 3 only | 1, 3 only | 2, 4 only | 4 only | All are correct |

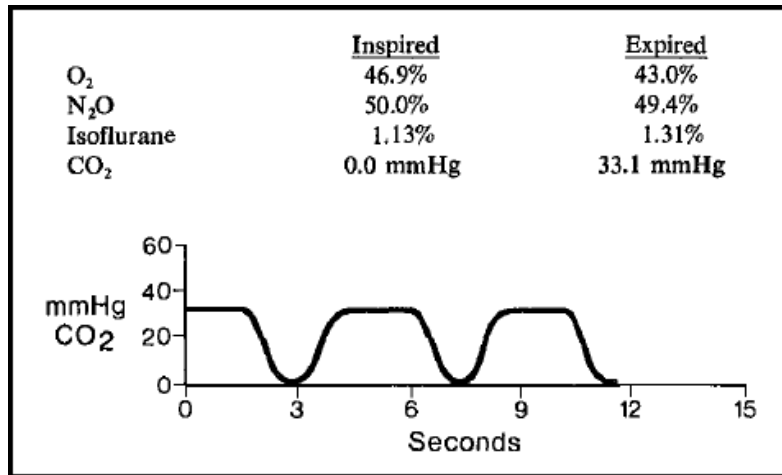

125. The mass spectrometer recording above was obtained 20 minutes after induction of anesthesia with nitrous oxide and isoflurane in a healthy, 40-kg 10-year-old child. A semiclosed circuit with a fresh gas flow of 5 L/min is being used. Correct interpretations include:

- (1) The expired isoflurane concentration reflects isoflurane partial pressure in the central nervous system
- (2) The expired isoflurane concentration will remain constant if inspired concentrations are held constant for the next 60 minutes
- (3) The ratio of expired to inspired isoflurane concentrations indicates higher inspired isoflurane concentrations earlier in the anesthetic
- (4) The ratio of expired to inspired nitrous oxide concentrations indicates a small leak in the breathing system

126. Expected findings in patients with inappropriate secretion of antidiuretic hormone include

- (1) urine osmolality greater than plasma osmolality
- (2) hypovolemia
- (3) hyponatremia
- (4) resolution following administration of desmopressin (DDAVP)

127. A 5-year-old child with a suspected brain tumor is scheduled to undergo MRI during general anesthesia. Compared with ketamine, propofol is more appropriate because it is associated with

- (1) better amnesia
- (2) more rapid emergence
- (3) less respiratory depression
- (4) a decrease in intracranial pressure

FOR EACH QUESTION FILL IN ONLY ONE CIRCLE ON YOUR ANSWER SHEET

Copyright© 1996 by the Joint Council on In-Training Examinations, American Board of Anesthesiology/American Society of Anesthesiologists. All rights Reserved. Reproduction of this Copyrighted Material is Prohibited.

DIRECTIONS SUMMARIZED

| | | | | |
|-----------------|--------------|--------------|-----------|--------------------|
| A | B | C | D | E |
| 1, 2, 3 only | 1, 3 only | 2, 4 only | 4 only | All are correct |

128. Conditions that may result in severe maternal hemorrhage include

- (1) abruptio placentae
- (2) placenta accreta
- (3) placenta previa
- (4) uterine atony

129. Intubation may be difficult in a patient with rheumatoid arthritis because of

- (1) ankylosis of the temporomandibular joint
- (2) arthritis of the cricoarytenoid cartilage
- (3) ankylosis of the cervical vertebrae
- (4) macroglossia

130. Following tracheal intubation, effects of placing a heated humidifier in the ventilator circuit include

- (1) decreased loss of heat from the lungs
- (2) increased mechanical dead space
- (3) preservation of mucociliary function
- (4) hyponatremia

131. Risk factors for halothane-induced hepatotoxicity include

- (1) multiple exposures to halothane
- (2) alcoholic cirrhosis
- (3) female gender
- (4) upper abdominal surgery

132. Problems that occur with increased frequency during the anesthetic management of patients with acromegaly include

- (1) polypoid pharyngeal masses
- (2) systemic hypertension
- (3) glucose intolerance
- (4) decreased subglottic diameter

133. A properly performed retrobulbar block results in

- (1) decreased intraocular pressure
- (2) akinesis of the globe
- (3) akinesis of the eyelids
- (4) transient loss of vision

FOR EACH QUESTION FILL IN ONLY ONE CIRCLE ON YOUR ANSWER SHEET

DIRECTIONS SUMMARIZED

| | | | | |
|-----------------|--------------|--------------|-----------|--------------------|
| A | B | C | D | E |
| 1, 2, 3 only | 1, 3 only | 2, 4 only | 4 only | All are correct |

134. In a patient who used cocaine two hours ago, the anesthesiologist should anticipate

- (1) ventricular dysrhythmias
- (2) decreased response to exogenous epinephrine
- (3) concomitant abuse of other substances
- (4) decreased anesthetic requirement

135. Extrajunctional acetylcholine receptors cause

- (1) succinylcholine-induced hyperkalemia
- (2) increased susceptibility to malignant hyperthermia
- (3) resistance to nondepolarizing agents
- (4) phase II block

136. Findings that indicate an increased risk for perioperative cardiac morbidity include

- (1) S₃ gallop
- (2) chronic diastolic blood pressure of 100 mmHg
- (3) Holter examination with ST-segment elevation of 3 mm
- (4) nonspecific ST-T changes on ECG

137. During general anesthesia for electroconvulsive therapy, anticipated changes include increases in

- (1) cerebral blood flow
- (2) systemic blood pressure
- (3) cerebral oxygen consumption
- (4) heart rate

138. A "tec" type variable bypass vaporizer

- (1) splits the fresh gas flow within the vaporizer
- (2) delivers higher concentrations at higher altitudes
- (3) has automatic temperature compensation
- (4) delivers agent concentrations independent of fresh gas composition

139. Complications of neostigmine therapy in a patient with myasthenia gravis include

- (1) sialorrhea
- (2) muscle weakness
- (3) miosis
- (4) dysphoria

FOR EACH QUESTION FILL IN ONLY ONE CIRCLE ON YOUR ANSWER SHEET

DIRECTIONS SUMMARIZED

| | | | | |
|-----------------|--------------|--------------|-----------|--------------------|
| A | B | C | D | E |
| 1, 2, 3 only | 1, 3 only | 2, 4 only | 4 only | All are correct |

140. During apnea, SpO₂ decreases more rapidly in a newborn than in an adult because of

- (1) fetal hemoglobin
- (2) increased functional residual capacity
- (3) increased dead space:tidal volume ratio
- (4) increased oxygen consumption per kg

141. Analgesia for tracheostomy requires block of which nerves?

- (1) Glossopharyngeal
- (2) Cervical nerves 2 through 4
- (3) Superior laryngeal
- (4) Recurrent laryngeal

142. True statements concerning epidural administration of morphine include:

- (1) The incidence of severe respiratory depression requiring antagonist therapy is 10% to 15%
- (2) The primary cause of analgesia is stimulation of descending inhibitory tracts
- (3) Pruritus is caused by central neurogenic histamine release
- (4) Nausea is caused by stimulation of supraspinal opioid receptors

143. Findings consistent with acute pulmonary thromboembolization include increased

- (1) airway resistance
- (2) pulmonary artery occlusion pressure
- (3) central venous pressure
- (4) PETCO₂

144. Respiratory parameters that are greater in neonates than in adults include

- (1) oxygen consumption (mL/kg/min)
- (2) vital capacity (mL/kg)
- (3) alveolar ventilation (mL/kg/min)
- (4) tidal volume (mL/kg)

145. Findings consistent with nitroprusside toxicity include

- (1) metabolic acidosis
- (2) increased oxygen consumption
- (3) tachyphylaxis
- (4) decreased mixed venous oxygen content

FOR EACH QUESTION FILL IN ONLY ONE CIRCLE ON YOUR ANSWER SHEET

DIRECTIONS SUMMARIZED

| | | | | |
|-----------------|--------------|-------------|-----------|--------------------|
| A | B | C | D | E |
| 1, 2, 3 only | 1, 3 only | 2,4 only | 4 only | All are correct |

146. During general anesthesia, a patient has the following measured parameters: PaO₂ 390 mmHg, SaO₂ 89%, and SpO₂ 89% at an FiO₂ of 0.98. Causes include

- (1) administration of prilocaine
- (2) methemoglobinemia
- (3) high-dose infusion of nitroglycerin
- (4) inhalation of carbon monoxide

147. Severe scoliosis increases the risk for perioperative

- (1) right ventricular failure
- (2) hypoxemia
- (3) hypercarbia
- (4) pulmonary edema

148. Factors that increase production of carbon dioxide during anesthesia include

- (1) hyperthyroidism
- (2) laparoscopic cholecystectomy
- (3) shivering
- (4) hyperalimentation primarily with lipids

149. Findings expected after release of a lower extremity tourniquet that has been inflated for 90 minutes include

- (1) increased PETCO₂
- (2) metabolic acidosis
- (3) decreased blood pressure
- (4) increased body temperature

150. Effects associated with prolonged administration of muscle relaxants to patients in the ICU include

- (1) tolerance
- (2) myopathy
- (3) prolonged paralysis
- (4) adrenal suppression

151. Systemic effects of induced hypothermia to 27°C include

- (1) a 50% to 60% decrease in systemic oxygen consumption
- (2) absent cerebral blood flow response to carbon dioxide
- (3) impaired platelet function
- (4) a shift of the oxyhemoglobin dissociation curve to the right

DIRECTIONS SUMMARIZED

| | | | | |
|-----------------|--------------|--------------|-----------|--------------------|
| A | B | C | D | E |
| 1, 2, 3 only | 1, 3 only | 2, 4 only | 4 only | All are correct |

152. A patient with untreated hyperthyroidism requires emergency surgery. Effects of anesthetic management with administration of esmolol include

- (1) decreased heart rate
- (2) prevention of hyperpyrexia
- (3) resolution of tremors
- (4) decreased thyroxine synthesis

153. A 68-year-old man with oxygen-dependent chronic obstructive pulmonary disease is scheduled to undergo total hip arthroplasty. Arterial blood gases are PaO₂ 54 mmHg, PaCO₂ 52 mmHg, and pH 7.38 with oxygen delivered through a nasal cannula at a rate of 2 L/min. Pulmonary function testing is most likely to show

- (1) decreased maximal midexpiratory flow rate
- (2) decreased functional residual capacity
- (3) FEV₁/FVC less than 50% of normal
- (4) normal total lung capacity

154. The increase in volume or pressure of an air-filled cavity by nitrous oxide is dependent on

- (1) partial pressure of nitrous oxide
- (2) solubility of nitrogen in the blood
- (3) duration of nitrous oxide administration
- (4) blood flow to the air-filled cavity

155. Drugs that impair hypoxic pulmonary vasoconstriction include

- (1) isoflurane
- (2) atropine
- (3) nitroprusside
- (4) nitrous oxide

156. A patient with chronic renal failure requires emergency surgery for removal of a ruptured spleen. Serum potassium concentration is 6.9 mEq/L. Appropriate actions to acutely decrease the serum potassium concentration include

- (1) intravenous administration of sodium bicarbonate
- (2) hyperventilation
- (3) intravenous administration of glucose and insulin
- (4) intravenous administration of calcium chloride

DIRECTIONS SUMMARIZED

| | | | | |
|-----------------|--------------|--------------|-----------|--------------------|
| A | B | C | D | E |
| 1, 2, 3 only | 1, 3 only | 2, 4 only | 4 only | All are correct |

157. A child with mild hemophilia A (without antibodies to clotting factors) requires emergency insertion of a rod for repair of an open femur fracture. Appropriate preoperative management includes

- (1) fresh frozen plasma
- (2) desmopressin (DDAVP)
- (3) plasmapheresis
- (4) factor VIII concentrate

158. After repair of an abdominal aneurysm, a 65-year-old man has a PaO₂ of 89 mmHg while being mechanically ventilated with 50% oxygen. Addition of positive end-expiratory pressure 6 cmH₂O will invariably cause

- (1) increased functional residual capacity
- (2) increased PaO₂
- (3) expansion of underventilated alveoli
- (4) decreased dead space ventilation

159. True statements concerning intraoperative transfusion of platelets include:

- (1) Platelets stored at 20 to 40°C survive longer after transfusion than those stored at 4°C
- (2) Platelets should be administered through a 40-micron filter
- (3) Desmopressin (DDAVP) decreases the requirement for platelet transfusion in patients with uremia
- (4) Most patients require platelet transfusion after rapid replacement of one blood volume

160. True statements concerning pressure-limited mechanical ventilation of a premature neonate include:

- (1) It is less likely to cause pulmonary barotrauma than volume-limited ventilation
- (2) Occlusion of the endotracheal tube will cause inspiratory pressure to increase above preset limits
- (3) Increasing inspiratory time will increase mean airway pressure
- (4) Tidal volume will remain constant despite compliance changes

161. An adult patient has been breathing spontaneously from a circle system for the past 90 minutes. The isoflurane vaporizer is set at 1%, but an agent analyzer shows an inspired isoflurane concentration of 0.7% and an end-tidal concentration of 0.5%. Explanations for this discrepancy include

- (1) decreased functional residual capacity
- (2) fresh gas flow rate
- (3) diluting effect of nitrous oxide
- (4) uptake of isoflurane from the alveoli

DIRECTIONS SUMMARIZED

| | | | | |
|-----------------|--------------|-------------|-----------|--------------------|
| A | B | C | D | E |
| 1, 2, 3 only | 1, 3 only | 2,4 only | 4 only | All are correct |

162. Appropriate treatment of acute perioperative adrenal insufficiency includes

- (1) isotonic crystalloid
- (2) dexamethasone
- (3) hydrocortisone
- (4) potassium

163. Cerebral autoregulation is preserved

- (1) in brain tissue adjacent to cerebral tumors
- (2) during hypothermic cardiopulmonary bypass with temperature-corrected pH management
- (3) during 2% isoflurane anesthesia
- (4) in a patient with treated chronic hypertension

164. In an evaluation of closed malpractice cases by the ASA, a comparison of pediatric and adult cases found that

- (1) respiratory events were more common in the pediatric age group
- (2) anesthetic care was judged to be substandard more often in the pediatric cases
- (3) mortality rate was higher in the pediatric age group
- (4) more than one third of the total claims were in the pediatric age group

165. Findings present 15 minutes after pulmonary aspiration of acidic, non particulate gastric contents include

- (1) increased PaCO₂ to PETCO₂ gradient
- (2) upward-sloping alveolar plateau on capnogram tracing
- (3) increased pulmonary compliance
- (4) increased alveolar-arterial oxygen tension difference

166. Compared with use of vecuronium in adults, use in neonates is characterized by

- (1) larger relative volume of distribution
- (2) lesser potentiation by inhalational anesthetics
- (3) effectiveness at lower plasma concentrations
- (4) longer elimination half-life

167. Drugs that increase heart rate in a patient one year after heart transplantation include

- (1) atropine
- (2) ketamine
- (3) pancuronium
- (4) epinephrine

FOR EACH QUESTION FILL IN ONLY ONE CIRCLE ON YOUR ANSWER SHEET

DIRECTIONS SUMMARIZED

| | | | | |
|-----------------|--------------|--------------|-----------|--------------------|
| A | B | C | D | E |
| 1, 2, 3 only | 1, 3 only | 2, 4 only | 4 only | All are correct |

168. A 6-year-old boy with rhinorrhea, malaise, and a dry cough is scheduled to undergo myringotomy during general anesthesia. Temperature is 37.8°C (100.1°F). He is at increased risk for

- (1) laryngospasm
- (2) intraoperative hypoxemia
- (3) bronchospasm
- (4) aspiration pneumonitis

169. When performing a stellate ganglion block via the anterior paratracheal approach, the final needle tip position should be

- (1) anterior to the prevertebral fascia
- (2) at the level of the thyroid cartilage
- (3) medial to the carotid artery
- (4) on the lateral aspect of the C7 transverse process

170. During spontaneous ventilation in infants, factors that would indicate use of a Bain circuit rather than an adult circle system include

- (1) more rapid rise of FA/FI
- (2) better airway humidification
- (3) less resistance to gas flow
- (4) use of lower fresh gas flow rates

171. True statements concerning the perioperative management of an infant with pulmonary atresia and an intact ventricular septum include:

- (1) The infant is cyanotic
- (2) The speed of intravenous induction will be decreased
- (3) Acute hemodynamic decompensation occurs if the ductus arteriosus closes
- (4) The speed of an inhalational induction will be increased

172. A 62-year-old man with a history of chronic ethanol abuse is scheduled to undergo debridement of an infected leg. He has received antibiotic therapy for two days and reports increasing nervousness and insomnia. Which of the following should be expected in this patient?

- (1) Peripheral neuropathy
- (2) Hyperglycemia
- (3) Grand mal seizure
- (4) Decreased anesthetic requirement

FOR EACH QUESTION FILL IN ONLY ONE CIRCLE ON YOUR ANSWER SHEET

DIRECTIONS SUMMARIZED

| | | | | |
|-----------------|--------------|--------------|-----------|--------------------|
| A | B | C | D | E |
| 1, 2, 3 only | 1, 3 only | 2, 4 only | 4 only | All are correct |

173. Maneuvers used to avoid complications of bilateral neurolytic celiac plexus block include

- (1) verifying correct needle placement with a test dose of lidocaine
- (2) infusing balanced saline solution 500 mL intravenously
- (3) inserting the needle with radiologic guidance
- (4) adding radiopaque dye to the neurolytic solution

174. Appropriate treatment of pelvic pain resulting from invasive cervical cancer includes

- (1) opioids
- (2) hypogastric plexus block
- (3) segmental epidural block
- (4) celiac plexus block

175. Effects of thiopental on the central nervous system include

- (1) decrease in the cerebral metabolic requirement for oxygen
- (2) direct vasoconstriction of cerebral arterioles
- (3) induction of EEG burst suppression
- (4) improvement in neurologic outcome after cardiac arrest

**1996 ABA/ASA IN-TRAINING EXAMINATION
ANSWER KEY
BOOK A**

This answer key reflects the state of knowledge in 1996, and is provided for instructional purposes only. The key was verified in 1996 through validation studies. A small number of questions were not graded for a variety of reasons, such as ambiguity or unanticipated presence of more than one potentially correct answer. You should verify the relevance of the questions or the correctness of the answers through your own studies.

The American Board of Anesthesiology Written Examination for Primary Certification is a subset of the ABA/ASA In-Training Examination. Approximately 80% of the questions were included in the grading of the ABA Written Examination, whereas the remainder were graded only for the ABA/ASA In-Training Examination.

| | | | | | | | | | | | |
|----|---|----|---|----|---|-----|---|-----|---|-----|---|
| 1 | D | 31 | B | 61 | B | 91 | E | 121 | A | 151 | D |
| 2 | C | 32 | E | 62 | A | 92 | D | 122 | B | 152 | B |
| 3 | E | 33 | A | 63 | A | 93 | D | 123 | C | 153 | A |
| 4 | D | 34 | B | 64 | E | 94 | C | 124 | A | 154 | A |
| 5 | E | 35 | B | 65 | A | 95 | C | 125 | D | 155 | D |
| 6 | E | 36 | B | 66 | E | 96 | E | 126 | C | 156 | C |
| 7 | D | 37 | B | 67 | E | 97 | E | 127 | D | 157 | B |
| 8 | C | 38 | E | 68 | A | 98 | A | 128 | A | 158 | E |
| 9 | B | 39 | C | 69 | B | 99 | C | 129 | B | 159 | D |
| 10 | C | 40 | B | 70 | B | 100 | A | 130 | D | 160 | B |
| 11 | B | 41 | C | 71 | A | 101 | C | 131 | D | 161 | A |
| 12 | A | 42 | B | 72 | D | 102 | B | 132 | A | 162 | C |
| 13 | D | 43 | B | 73 | E | 103 | D | 133 | B | 163 | B |
| 14 | A | 44 | E | 74 | D | 104 | A | 134 | C | 164 | E |
| 15 | C | 45 | E | 75 | B | 105 | B | 135 | B | 165 | B |
| 16 | C | 46 | D | 76 | A | 106 | D | 136 | E | 166 | C |
| 17 | E | 47 | C | 77 | E | 107 | A | 137 | D | 167 | B |
| 18 | C | 48 | A | 78 | B | 108 | A | 138 | E | 168 | A |
| 19 | A | 49 | E | 79 | C | 109 | D | 139 | A | 169 | B |
| 20 | E | 50 | D | 80 | E | 110 | B | 140 | E | 170 | C |
| 21 | C | 51 | E | 81 | D | 111 | B | 141 | B | 171 | A |
| 22 | B | 52 | B | 82 | A | 112 | B | 142 | B | 172 | A |
| 23 | D | 53 | A | 83 | D | 113 | B | 143 | C | 173 | B |
| 24 | A | 54 | A | 84 | D | 114 | C | 144 | E | 174 | D |
| 25 | C | 55 | B | 85 | E | 115 | B | 145 | B | 175 | D |
| 26 | D | 56 | B | 86 | A | 116 | D | 146 | B | | |
| 27 | A | 57 | A | 87 | A | 117 | A | 147 | B | | |
| 28 | C | 58 | A | 88 | D | 118 | E | 148 | D | | |
| 29 | C | 59 | C | 89 | D | 119 | C | 149 | E | | |
| 30 | E | 60 | A | 90 | D | 120 | B | 150 | A | | |

**1996 ABA/ASA IN-TRAINING EXAMINATION
ANSWER KEY
BOOK B**

This answer key reflects the state of knowledge in 1996, and is provided for instructional purposes only. The key was verified in 1996 through validation studies. A small number of questions were not graded for a variety of reasons, such as ambiguity or unanticipated presence of more than one potentially correct answer. You should verify the relevance of the questions or the correctness of the answers through your own studies.

The American Board of Anesthesiology Written Examination for Primary Certification is a subset of the ABA/ASA In-Training Examination. Approximately 80% of the questions were included in the grading of the ABA Written Examination, whereas the remainder were graded only for the ABA/ASA In-Training Examination.

| | | | | | | | | | | | |
|----|---|----|---|----|---|-----|---|-----|---|-----|---|
| 1 | B | 31 | B | 61 | D | 91 | C | 121 | B | 151 | B |
| 2 | E | 32 | E | 62 | A | 92 | C | 122 | A | 152 | B |
| 3 | E | 33 | E | 63 | B | 93 | B | 123 | C | 153 | B |
| 4 | C | 34 | A | 64 | E | 94 | A | 124 | B | 154 | E |
| 5 | C | 35 | C | 65 | A | 95 | C | 125 | B | 155 | B |
| 6 | B | 36 | A | 66 | A | 96 | D | 126 | B | 156 | A |
| 7 | B | 37 | D | 67 | D | 97 | B | 127 | C | 157 | C |
| 8 | C | 38 | C | 68 | B | 98 | B | 128 | E | 158 | B |
| 9 | A | 39 | D | 69 | B | 99 | B | 129 | A | 159 | B |
| 10 | C | 40 | A | 70 | C | 100 | D | 130 | B | 160 | B |
| 11 | B | 41 | A | 71 | B | 101 | A | 131 | B | 161 | C |
| 12 | D | 42 | B | 72 | D | 102 | E | 132 | E | 162 | B |
| 13 | B | 43 | B | 73 | D | 103 | D | 133 | C | 163 | D |
| 14 | C | 44 | B | 74 | E | 104 | A | 134 | B | 164 | A |
| 15 | D | 45 | A | 75 | A | 105 | A | 135 | B | 165 | C |
| 16 | D | 46 | C | 76 | B | 106 | B | 136 | B | 166 | B |
| 17 | E | 47 | B | 77 | B | 107 | C | 137 | E | 167 | C |
| 18 | C | 48 | C | 78 | D | 108 | A | 138 | A | 168 | A |
| 19 | B | 49 | E | 79 | D | 109 | E | 139 | A | 169 | B |
| 20 | B | 50 | E | 80 | B | 110 | E | 140 | D | 170 | B |
| 21 | D | 51 | C | 81 | E | 111 | B | 141 | C | 171 | B |
| 22 | E | 52 | D | 82 | C | 112 | D | 142 | D | 172 | B |
| 23 | C | 53 | D | 83 | D | 113 | B | 143 | B | 173 | E |
| 24 | E | 54 | D | 84 | E | 114 | A | 144 | B | 174 | A |
| 25 | A | 55 | E | 85 | B | 115 | A | 145 | B | 175 | B |
| 26 | D | 56 | C | 86 | E | 116 | E | 146 | A | | |
| 27 | B | 57 | A | 87 | E | 117 | B | 147 | A | | |
| 28 | A | 58 | D | 88 | D | 118 | B | 148 | B | | |
| 29 | E | 59 | E | 89 | A | 119 | D | 149 | A | | |
| 30 | C | 60 | B | 90 | B | 120 | E | 150 | A | | |